

**CaterMarket**  
FOOD SERVICE EQUIPMENT

**CATERING  
EQUIPMENT  
CATALOGUE**

**2022-23**

EDITION #1



## ABOUT US

CaterMarket was established in 1998 in Cape Town and since then expanded into a well-known supplier of food service equipment that specialises in the supply and maintenance of catering and refrigeration equipment to the food service and hospitality industry.

Our Johannesburg branch was opened in 2015, to increase our footprint and back up service in Southern Africa. The growth of this branch has exceeded all expectations and has become one of the preferred suppliers of food service equipment in the area.

Our experienced staff understand and meet the needs of our clients and are passionate about providing full pre and post sales advice. We carry a wide range of products to meet the specific requirements of our clients.

## QUICK NAVIGATION

FOOD PREPARATION	4 - 19	PACKAGING	20 - 25
COOKING EQUIPMENT	26 - 89	BEVERAGE	90 - 103
WASHING & HARDWARE	104 - 115	BUFFET WARE	116 - 127
REFRIGERATION	128 - 149	DISPLAY & RETAIL	150 - 167
HOLDING & DISTRIBUTION	168 - 185	STORAGE & HANDLING SOLUTIONS	186 - 195

## YOUR COMPLETE KITCHEN SOLUTION

1

### PLAN & DESIGN

We recognize that each client has different needs and we assist them with specific designs and kitchen lay-outs best suited to achieve their individual goals. Once the lay-out of your kitchen has been agreed upon we supply the electrical and plumbing lay-outs and attend site meetings to liaise with the contractors to ensure correct service installation.

2

### SUPPLY

The best equipment for your needs will be custom designed and produced locally or supplied from our imported ranges. We carry a wide range of products to meet the specific needs of our clients.

3

### INSTALLATION

Installations are done by our experienced technicians to ensure that everything is fitted correctly and functioning properly.

4

### TRAINING

We offer training to staff on the correct handling and operation of the equipment once installation is completed.

5

### MAINTENANCE

Our skilled service technicians in our workshops are fully equipped to provide a full back-up service for all our electrical, gas and refrigeration equipment.

 ***BakeMark***



**SMARTBLEND**

*Smoothies  
Cocktails  
Shakes  
Soups  
Puree*



**VORTEX<sub>SC</sub>**



**VORTEX**



**STORM**

## SECTION INDEX

Blades for Veg prep machine .....	6
Blenders .....	7
Bowl Cutters .....	8
Bread mixers .....	15
Cake mixers .....	12-14
Chip cutters .....	9
Cold meat slicers .....	11
Dough divider & rounder .....	17
Dough mixers .....	15-16
Dough rollers .....	18
Dough sheeters .....	19
Food processors .....	8
Fry cutters .....	9
Kitchen assistant .....	12
Meat slicers .....	11
Mixers .....	12-16
Pastry sheeters .....	19
Pizza dough rollers .....	18
Planetary mixers .....	12-14
Polony slicers .....	11
Potato chippers .....	9
Slicers .....	11
Smoothie makers .....	7
Spiral dough mixers .....	15-16
Spiral potato cutter .....	10
Vegetable preparation machines .....	6





## FEATURES

- Aluminium and magnesium alloy body
- Fitted with a safety micro switch to stop operation when cover is opened
- Ventilated motor, allowing continuous operation
- Motor thermal protection against over heating
- Removable hinged lid equipped with a large half moon hopper and cylindrical hopper
- Rounded edges for easy cleaning
- Easy to operate
- Feeder stick and cleaning brush included
- Fitted with (4x) non-slip rubber feet

## SPECIFICATIONS

MODEL	SmartChef HLC-300
ELECTRICITY	0.55kW, 220V, Single Phase
DIMENSIONS	200 x 490 x 500mm high
WEIGHT	23kg
SPEED	375rpm - Single speed
HOPPER DIM	Large half moon - 104cm <sup>2</sup> Cylindrical 58mm diameter
BLADES INCLUDED	2mm slicer 4mm slicer 2mm grater 3mm grater 7mm grater

ORDER CODE

VPS0001



## OPTIONAL BLADES

### GRATING BLADES



CUT DIM.	ORDER CODE
3mm	VPS1003
4mm	VPS1004
7mm	VPS1007

### JULIENNE BLADES



CUT DIM.	ORDER CODE
2.5mm	VPS5025
4mm	VPS5004
8mm	VPS5008
10mm	VPS5010

### SLICING BLADES



CUT DIM.	ORDER CODE
2mm	VPS2002
4mm	VPS2004
8mm	VPS2008
10mm	VPS2010
14mm	VPS2014

### CURVED SLICING BLADES



CUT DIM.	ORDER CODE
1mm	VPS3001
2mm	VPS3002
5mm	VPS3005

### CHIPPING BLADES must be used with a slicing disk

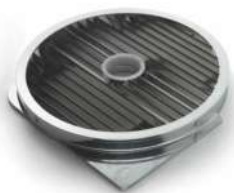

CUT DIM.	ORDER CODE
8mm	VPS4008
10mm	VPS4010

### DICING BLADES must be used with a slicing disk



CUT DIM.	ORDER CODE
8mm	VPS6008
10mm	VPS6010
12mm	VPS6012
20mm	VPS6020

### EJECTOR PLATE

ORDER CODE	VPS9000
------------	---------



**FEATURES**

- Modern design ABS housing with an “unbreakable” food grade Polycarbonate jar
- Easy to use digital touch control panel with various speed, time and pulse action
- Polycarbonate soundproof cover to reduce noise
- Fitted with a stainless steel blade assembly
- Removable dosing cup and stir bar included
- Fitted with an over-heat, auto shut-off safety function
- Industrial grade, heavy duty motor with pure copper coil
- Housing fitted with non-slip base

**WITH SOUND COVER**

**SPECIFICATIONS**

MODEL	SmartBlend VORTEX SC 1680C
ELECTRICITY	1.68kW, 220V, Single Phase
DIMENSIONS	230 x 250 x 540mm high (closed) 230 x 250 x 790mm high (open)
WEIGHT	9kg
SPEED	32 000rpm - Touch control
JAR CAPACITY	2Lt



**ORDER CODE**

**BSB1680C/C**

**FEATURES**

- ABS housing with “unbreakable” food grade Polycarbonate jar
- Precision blending with pulse action
- Fitted with an over-heat, auto shut-off safety function
- Industrial grade, heavy duty motor with pure copper coil
- Variable speed control
- Fitted with a stainless steel blade assembly
- Removable dosing cup and stir bar included
- Housing fitted with non-slip base



**SPECIFICATIONS**

MODEL	SmartBlend VORTEX 1680
ELECTRICITY	1.68kW, 220V, Single Phase
DIMENSIONS	230 x 250 x 520mm high
WEIGHT	6kg
SPEED	32 000rpm - Analog control
JAR CAPACITY	2Lt

**ORDER CODE**

**BSB1680**



**SPECIFICATIONS**

MODEL	SmartBlend STORM 112
ELECTRICITY	1.1kW, 220V, Single Phase
DIMENSIONS	225 x 210 x 490mm high
WEIGHT	4kg
SPEED	26 000rpm - Analog control
JAR CAPACITY	2Lt

**ORDER CODE**

**BSB0112**

**OPTIONAL EXTRAS**

**2Lt JAR & TAMPER**

Compatible with - VORTEX SC 1680C & VORTEX 1680

**ORDER CODE**

**BSB1680-JAR2L**

**2Lt JAR & TAMPER**

Compatible with - STORM 112

**ORDER CODE**

**BSB0112-JAR2L**

## FEATURES

- Robust stainless steel body and bowl
- Lid is fitted with a large dosing cup to easily add liquid
- EMP.SD.01Y - Digital push stop/start button
- Fitted with a safety switch
- Transparent cover for easy viewing of product
- Easy removable cutting bowl and blades
- EMP.SD.15 - Double circuit timer with digital control panel
- Fitted with (4x) non-slip feet



## 8 LITRE TABLE MODEL

### SPECIFICATIONS

MODEL	Empero SD.01Y
ELECTRICITY	0.37kW, 220V, Single Phase
DIMENSIONS	295 x 490 x 365mm high
WEIGHT	20kg
SPEED	1400rpm - Single speed
BOWL DIM	240 x 180mm deep
BOWL CAPACITY	8Lt

**ORDER CODE**                      **EMP.SD.01Y**



## 15 LITRE TABLE MODEL

### SPECIFICATIONS

MODEL	Empero SD.15
ELECTRICITY	0.90kW, 380V, 3 Phase + N
DIMENSIONS	380 x 625 x 515mm high
WEIGHT	46kg
SPEED	750 ~ 1500rpm
BOWL DIM	290 x 220mm deep
BOWL CAPACITY	15Lt

**ORDER CODE**                      **EMP.SD.15**



## FEATURES

- Robust stainless steel body and bowl
- Transparent cover for easy viewing of the product
- Lid is fitted with a large dosing cup to easily add liquid
- Easy removable blade and bowl
- Fitted with a bowl tilting mechanism
- Double circuit timer and digital control panel
- Fitted with a safety switch

## 50 LITRE FLOOR STANDING

### SPECIFICATIONS

MODEL	Empero SD.09
ELECTRICITY	5.5kW, 380V, 3 Phase + N
DIMENSIONS	720 x 685 x 1245mm high
WEIGHT	70kg
SPEED	750 ~ 1500rpm
BOWL DIM	400 x 400mm
BOWL CAPACITY	50Lt

**ORDER CODE**                      **EMP.SD.09**





### FEATURES

- Heavy-duty, nickel-plated ductile cast iron frame and handle
- Clean and durable stainless steel "V" trough for smooth operation
- Sure grip handle
- 290mm long at base
- 160mm height opening for loading vegetables
- Screw holes on base of legs for permanent mounting to table or wall
- Optional wall bracket available for ease of operation

### SPECIFICATIONS

DIMENSIONS 340 x 210 x 350mm high  
WEIGHT 7kg

MODEL Vollrath 47713  
CUT SIZE 7mm  
ORDER CODE **FCV0007**

MODEL Vollrath 47715  
CUT SIZE 11mm  
ORDER CODE **FCV0011**

**OPTIONAL WALL BRACKET**  
ORDER CODE **FCV0000**



### FEATURES

- Heavy-duty, cast aluminum frame and handle
- Clean and durable stainless steel "V" trough for smooth operation
- Sure grip handle
- Screw holes on base of legs for permanent mounting to table or wall
- Supplied with 8, 10 and 12mm interchangeable blade sets
- Optional wall bracket available for ease of operation

### SPECIFICATIONS

MODEL SmartChef HC-02  
DIMENSIONS 430 x 220 x 330mm high  
CUT SIZE 8/10/12mm  
WEIGHT 3.5kg  
ORDER CODE **FCS0009**

**OPTIONAL WALL BRACKET**  
ORDER CODE **WBS0000**



### FEATURES

- Heavy-duty, cast aluminum frame and handle
- Easy interchangeable block and blade
- Easy to operate
- Maximum potato size - 150mm
- Fitted with a heavy-duty spring
- Optional chipper bridge available

### SPECIFICATIONS

DIMENSIONS 330 x 140 x 640mm high  
WEIGHT 4kg

MODEL SmartChef HC-01/6  
CUT HOLES & SIZE 6 x 6 / 14mm  
ORDER CODE **CHS0006**

MODEL SmartChef HC-01/7  
CUT HOLES & SIZE 7 x 7 / 12mm  
ORDER CODE **CHS0007**

**OPTIONAL CHIPPER BRIDGE**  
ORDER CODE **CBS0000**

# SPIRAL POTATO CUTTER

**SmartChef**



## FEATURES

- Manufactured from stainless steel
- Fitted with a replaceable stainless steel blade
- Fixed shaft with hole for the bamboo sign
- Fitted with (4x) non-slip rubber feet

## SPECIFICATIONS

MODEL SmartChef HSP-01  
DIMENSIONS 340 x 130 x 140mm high  
WEIGHT 1kg

ORDER CODE SPC0001

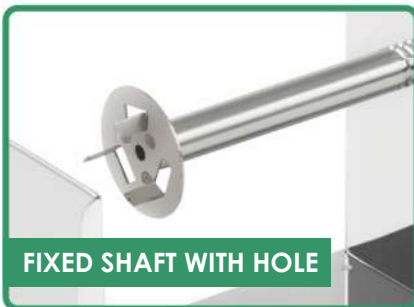

## SPIRAL POTATOES IN 4 EASY STEPS



INSERT BAMBOO SIGN THROUGH POTATO



INSERT POTATO INTO SPIRAL CUTTER



ROTATE HANDLE UNTIL CUT THROUGH



REMOVE, FRY AND SERVE



## FEATURES

- The slicer is built with polished cast aluminum
- Easy to use and clean with little maintenance
- Double ball bearing blade support
- Double stone sharpening accessory included
- Strong fan silenced with professional motor
- Very sturdy design
- The blade is made from non-sticking steel
- Sliding carriage on Teflon bushings with a heavy duty food holder
- Two button on-off switch
- Fitted with 4 non-slip feet



## SPECIFICATIONS

MODEL	Celme FY220
ELECTRICITY	0.16kW, 220V, Single Phase
DIMENSIONS	440 x 360 x 330mm high
WEIGHT	10kg
BLADE DIAMETER	220mm
SLICE THICKNESS	0 ~ 16mm
USEFUL CUT	220 x 165mm

**ORDER CODE**

**MSC0220**



## SPECIFICATIONS

MODEL	Celme Family 275
ELECTRICITY	0.16kW, 220V, Single Phase
DIMENSIONS	530 x 420 x 390mm high
WEIGHT	15kg
BLADE DIAMETER	275mm
SLICE THICKNESS	0 ~ 16mm
USEFUL CUT	230 x 180mm

**ORDER CODE**

**MSC0275**



## SPECIFICATIONS

MODEL	Celme Family 300
ELECTRICITY	0.22kW, 220V, Single Phase
DIMENSIONS	580 x 470 x 420mm high
WEIGHT	21kg
BLADE DIAMETER	300mm
SLICE THICKNESS	0 ~ 16mm
USEFUL CUT	245 x 195mm

**ORDER CODE**

**MSC0300**





**SUPPLIED WITH**

- 7Lt stainless steel beater bowl
- Polyethylene bowl cover
- Dough scraper & spatula
- 3.5Lt clear plastic beater bowl
- Dough roller
- Balloon whisk
- Dough hook
- Cookie beater

**FEATURES**

- Cast aluminum body
- The open bowl makes it easy to add ingredients and see the dough
- The bowl spins on the assistant base
- The weighted base bottom creates stability
- Multi functional - more than 16 different functions
- Fitted with 12 minute timer
- Variable speed control

**SPECIFICATIONS**

MODEL Ankarsrum Assistant Original  
 ELECTRICITY 1.5kW, 220V, Single Phase  
 DIMENSIONS 270 x 360 x 370mm high  
 WEIGHT 9kg  
 DRY FLOUR CAPACITY 3kg  
 CAPACITY 7Lt / 5kg  
 PLANETARY SPEED 45 ~ 130rpm

**ORDER CODE**

**AKM6230**



## OPTIONAL EXTRAS



## DELUXE PACKAGE INCLUDES

- 3 Sausage horns 10 / 20 / 25mm
- Feeder tray & feeder plug
- 4 x hole discs plates 2.5 / 4.5 / 6 / 8mm
- Mincer
- Grater
- Cookie attachment
- Citrus press
- Strainer
- Pasta discs
- Blender jug
- Splash guard for mincer

ORDER CODE

AKM920900067

## INDIVIDUAL ATTACHMENTS



Meat mincer & sausage horn 10 / 20 / 25mm  
AKM920900057



Hole discs for mincer 2,5 / 4,5 / 6 / 8mm  
AKM920900052/3/4/5



Grater attachment for mincer  
AKM920900034



Strainer attachment for mincer  
AKM920900033



Cookie attachment for mincer  
AKM920900035



Pasta discs for mincer  
AKM920900036



1.5Lt Blender jug  
AKM920900066



1.2Lt Citrus press  
AKM920900026



Vegetable cutter  
AKM920900043



Extra grating drums  
AKM920900044



Pasta roller - Lasagne  
AKM920900063



Pasta cutter - Fettuccine  
AKM920900064



Pasta cutter - Spaghetti  
AKM920900065



Flour and coffee grinder  
AKM920900045



Flake mill  
AKM920900046

## COLOUR OPTIONS



MATTE BLACK  
AKM6230B



BLACK DIAMOND  
AKM6230BD



JUBILEE SILVER  
AKM6230JS



ROYAL BLUE  
AKM6230RB



OCEAN BLUE  
AKM6230OB



FOREST GREEN  
AKM6230FG



CREME  
AKM6230C



LIGHT CREME  
AKM6230CL



MINERAL WHITE  
AKM6230MW



RED  
AKM6230R



PURE ORANGE  
AKM6230PO



SUNBEAM YELLOW  
AKM6230SY



**FEATURES**

- All metal construction with enamel coating
- Bowl can be lifted and lowered with the wheel action lifting mechanism
- Fitted with safety guard
- 3 Speed options
- Supplied with 3 attachments:
  - Whisk for stirring liquids and beating eggs
  - Flat beater for mixing soft batter
  - Dough hook for mixing soft dough batter

**SUPPLIED ATTACHMENTS**



**DOUGH HOOK**



**FLAT BEATER**



**WIRE WHISK**

**10 LITRE**

**SPECIFICATIONS**

MODEL BakeMark B10-BL  
ELECTRICITY 0.37kW, 220V, Single Phase  
DIMENSIONS 444 x 360 x 650mm high  
WEIGHT 50kg  
DRY FLOUR CAPACITY 1kg  
SPEED 110 / 220 / 420rpm  
DRIVE METHOD Gear

**ORDER CODE** **PMB0010**



**20 LITRE**

**SPECIFICATIONS**

MODEL BakeMark B20-BL  
ELECTRICITY 1.1kW, 220V, Single Phase  
DIMENSIONS 513 x 405 x 762mm high  
WEIGHT 65kg  
DRY FLOUR CAPACITY 3kg  
SPEED 110 / 220 / 420rpm  
DRIVE METHOD Gear

**ORDER CODE** **PMB0020**



**30 LITRE**

**SPECIFICATIONS**

MODEL BakeMark B30-B  
ELECTRICITY 1.5kW, 220V, Single Phase  
DIMENSIONS 545 x 440 x 882mm high  
WEIGHT 82kg  
DRY FLOUR CAPACITY 6kg  
SPEED 110 / 220 / 420rpm  
DRIVE METHOD Gear

**ORDER CODE** **PMB0030**



**40 LITRE**

**SPECIFICATIONS**

MODEL BakeMark B40-B  
ELECTRICITY 2kW, 220V, Single Phase  
DIMENSIONS 620 x 630 x 1011mm high  
WEIGHT 150kg  
DRY FLOUR CAPACITY 8kg  
SPEED 65 / 102 / 296rpm  
DRIVE METHOD Belt

**ORDER CODE** **PMB0040**



# SPIRAL DOUGH MIXERS FLOOR STANDING



## FEATURES

- Robust construction
- The particular shape of the spiral allows for a perfectly mixed dough
- Bowl, spiral, central column and protection grid is made from stainless steel
- Oil bath gear motor provides a particular silent transmission system
- Fitted with protection grid for increased safety
- Two speed motor is available on request on 3 Phase models
- Fitted with a 60 minute timer
- Fitted with an Emergency Stop switch
- Fitted with non-slip feet

## 10 LITRE

### SPECIFICATIONS

MODEL	BakeMark HS10
ELECTRICITY	0.75kW, 220V, Single Phase
DIMENSIONS	540 x 315 x 770mm high
WEIGHT	60kg
DOUGH WEIGHT	7kg
SHAFT SPEED	250 rpm
BOWL SPEED	25 rpm

ORDER CODE **DMB0010**



## 20 LITRE

### SPECIFICATIONS

MODEL	BakeMark BHS20A
ELECTRICITY	1.5kW, 220V, Single Phase
DIMENSIONS	700 x 500 x 770mm high
WEIGHT	75kg
DOUGH WEIGHT	16kg
SHAFT SPEED	125 / 250 rpm
BOWL SPEED	12.5 / 25 rpm

ORDER CODE **DMB0020**



## 30 LITRE

### SPECIFICATIONS

MODEL	BakeMark BHS30A
ELECTRICITY	2kW, 220V, Single Phase
DIMENSIONS	770 x 550 x 850mm high
WEIGHT	114kg
DOUGH WEIGHT	25kg
SHAFT SPEED	125 / 250 rpm
BOWL SPEED	12.5 / 25 rpm

ORDER CODE **DMB0030**



## 50 LITRE

### SPECIFICATIONS

MODEL	BakeMark HS50
ELECTRICITY	2.2kW, 380V, 3 Phase + N
DIMENSIONS	770 x 550 x 850mm high
WEIGHT	160kg
DOUGH WEIGHT	42kg
SHAFT SPEED	125 / 250 rpm
BOWL SPEED	12.5 / 25 rpm

ORDER CODE **DMB0050**





## FEATURES

- Robust construction
- The particular shape of the spiral allows for a perfectly mixed dough
- Bowl, spiral, central column and protection grid is made from stainless steel
- Oil bath gear motor provides a particular silent transmission system
- Fitted with protection grid for increased safety
- Two speed motor is available on request on 3 Phase models
- Fitted with a 30 minute timer
- Fitted with castors for ease of movement and cleaning

## 20 LITRE

### SPECIFICATIONS

MODEL	Prismafood IBM 20
ELECTRICITY	0.75kW, 220V, Single Phase
DIMENSIONS	430 x 740 x 860mm high
WEIGHT	62kg
DOUGH WEIGHT	17kg
BOWL DIAMETER	360mm
OUTPUT	Up to 56kg per hour

ORDER CODE

DMP1020



## 30 LITRE

### SPECIFICATIONS

DIMENSIONS	440 x 770 x 770mm high
WEIGHT	87kg
DOUGH WEIGHT	25kg
BOWL DIAMETER	400mm
OUTPUT	Up to 88kg per hour

MODEL

Prismafood IBM 30

ELECTRICITY

1.1kW, 220V, Single Phase

ORDER CODE

DMP1030

MODEL

Prismafood IBT 30

ELECTRICITY

1.1kW, 380V, 3 Phase + N

ORDER CODE

DMP3030



## 50 LITRE

### SPECIFICATIONS

MODEL	Prismafood IBT 50
ELECTRICITY	1.5kW, 380V, 3 Phase + N
DIMENSIONS	480 x 790 x 820mm high
WEIGHT	98kg
DOUGH WEIGHT	42kg
BOWL DIAMETER	450mm
OUTPUT	Up to 128kg per hour

ORDER CODE

DMP3050





# DOUGH DIVIDER & ROUNDER SEMI-AUTOMATIC



## FEATURES

- Heavy duty rigid cast iron construction
- Heat treated enamel finish resists rust, scratches and dents
- Dual stage, semi-automatic operation
- Stainless steel cutting knives, divides dough into 30 equal pieces
- Self-lubricating, enclosed motor for food safety and low maintenance
- The weight of the dough pieces can be adjusted between 30 and 100g
- Includes two divider rounder plates

## SPECIFICATIONS

MODEL	BakeMark HLM-30S
ELECTRICITY	0.75kW, 220V, Single Phase
DIMENSIONS	550 x 720 x 1350mm high
WEIGHT	290kg
OUTPUT	30pcs
DOUGH WEIGHT	30 ~ 100g per piece
PROCESSING TIME	10 ~ 13 seconds

## ORDER CODE

DDR-HLM-30S



## FEATURES

- Machine body manufactured from stainless steel
- Fitted with exclusive, patented automatic "Touch and Go" system. Sensors automatically switch the machine on when the operator puts dough onto the slope
- The working time can be set from 10 - 35 seconds
- Thickness adjustment knob on rollers
- Rollers are protected in transparent plexiglass for maximum safety with optimal visibility
- Easy to operate
- DMA 500/1 - Supplied with an electric foot pedal
- Can be mounted onto a table for increased stability



## DOUBLE ROLLER TILTED

### SPECIFICATIONS

MODEL	Prismafood DSA 420 T.G.O
ELECTRICITY	0.25kW, 220V, Single Phase
DIMENSIONS	585 x 330 x 790mm high
WEIGHT	36kg
PIZZA BASE DIAMETER	260 ~ 400mm
BASE THICKNESS	1 ~ 5mm
DOUGH WEIGHT	210 ~ 700gr

ORDER CODE

PRP0040



- Tilted upper roller
- Ideal for round pizza thanks to the presence of the central sling bar



## DOUBLE ROLLER PARALLEL

### SPECIFICATIONS

MODEL	Prismafood DSA 420 RP T.G.O
ELECTRICITY	0.25kW, 220V, Single Phase
DIMENSIONS	585 x 330 x 790mm high
WEIGHT	36kg
PIZZA BASE DIAMETER	260 ~ 400mm
BASE THICKNESS	1 ~ 5mm
DOUGH WEIGHT	210 ~ 700g

ORDER CODE

PRP0041



- Parallel rollers
- Ideal for pizza on tray (rectangular shape)



## SINGLE ROLLER

### SPECIFICATIONS

MODEL	Prismafood DMA 500/1
ELECTRICITY	0.25kW, 220V, Single Phase
DIMENSIONS	650 x 345 x 430mm high
WEIGHT	27kg
PIZZA BASE DIAMETER	260 ~ 450mm
BASE THICKNESS	1 ~ 5mm
DOUGH WEIGHT	210 ~ 700g

ORDER CODE

PRP0050





- FEATURES**
- Machine body manufactured from stainless steel
  - Overload protection and open-phase protection function
  - Collapsible for space saving purposes
  - Fitted with (4x) casters, 2 lockable



**630mm BELT SPECIFICATIONS**

MODEL BakeMark QS-630B  
 ELECTRICITY 1.1kW, 220V, Single Phase  
 EXPANDED DIMENSIONS 1000 x 3100 x 1100mm high  
 STOWED DIMENSIONS 1000 x 720 x 1700mm high  
 WEIGHT 268kg  
 MAX. DOUGH CAPACITY 6.5kg  
 BELT SIZE 630 x 2400mm  
 ROLLER ADJUSTABLE GAP 1 ~ 40mm

**ORDER CODE**

**PSB-QS-630B**



**400mm BELT SPECIFICATIONS**

MODEL BakeMark QS-400B  
 ELECTRICITY 0.4kW, 220V, Single Phase  
 EXPANDED DIMENSIONS 760 x 2000 x 1040mm high  
 STOWED DIMENSIONS 760 x 620 x 1310mm high  
 WEIGHT 160kg  
 MAX. DOUGH CAPACITY 4kg  
 BELT SIZE 400 x 1600mm  
 ROLLER ADJUSTABLE GAP 1 ~ 35mm

**ORDER CODE**

**PSB-QS-400B**





***SmartVac***

## SECTION INDEX

Continuous sealers .....	24
Double chamber vacuum sealers .....	22
Hand-press impulse sealers .....	25
Heat sealing machines .....	25
Horizontal continuous sealers .....	24
Impulse sealers .....	25
Single chamber vacuum sealers .....	23
Vacuum sealers .....	22-23
Vertical continuous sealers .....	24
Wrapping machines .....	25





**FEATURES**

- External structure and chamber made from stainless steel
- Double alternating chambers increases productivity
- Spring loaded lid stabilising arms for easy operation
- Fitted with stainless steel lid handles
- High density lid gasket for superior sealing during routine work
- Waterproof digital control panel
- Automatic vacuum extraction and sealing
- Can seal multiple types of materials
- Fitted with (4x) castors

**500mm SEALING BAR (FLOOR STANDING)**

**SPECIFICATIONS**

MODEL	SmartVac DZ-500/2SB
ELECTRICITY	220V, Single Phase
PUMP / SEAL POWER	2kW / 0.8kW
DIMENSIONS	1250 x 650 x 970mm high
CHAMBER SIZE	(2x) 540 x 420 x 150mm deep
SEALING BAR	(4x) 500 x 10mm
WEIGHT	186kg
OUTPUT	2-6 times/min

**ORDER CODE**

**VPS0500**



**DOUBLE CHAMBERS**

- Work in turns
- Increased efficiency
- More convenience



## FEATURES

- External structure and chamber made from stainless steel
- Wide lid opening for easy operation
- Waterproof digital control panel
- DZ450, DZ300 & DZ260C Fitted with 4 non-slip feet
- Clear Plexiglas domed-lid allows for full view of process
- High density lid gasket for superior sealing during routine work
- Automatic vacuum extraction, \*gas flushing and sealing
- DZ400 fitted with (4x) castors

\* Option available for Models DZ300 and DZ400



### 400mm SEALING BAR (FLOOR STANDING)



#### SPECIFICATIONS

ELECTRICITY	220V, Single Phase
PUMP / SEAL POWER	0.9kW / 0.8kW
DIMENSIONS	530 x 490 x 950mm high
CHAMBER SIZE	420 x 440 x 70mm deep
SEALING BAR	(2x) 400 x 10mm
WEIGHT	62kg
OUTPUT	2-4 times/min

#### WITHOUT GAS FLUSH

MODEL	SmartVac DZ-400
ORDER CODE	VPS0400

#### WITH GAS FLUSH

MODEL	SmartVac DZ-400G
ORDER CODE	VPS0400-GF

### 300mm SEALING BAR (TABLE MODEL)



#### SPECIFICATIONS

ELECTRICITY	220V, Single Phase
PUMP / SEAL POWER	0.3kW / 0.7kW
DIMENSIONS	570 x 460 x 430mm high
CHAMBER SIZE	382 x 320 x 50mm deep
SEALING BAR	300 x 8mm
WEIGHT	38kg
OUTPUT	2-4 times/min

#### WITHOUT GAS FLUSH

MODEL	SmartVac DZ-300
ORDER CODE	VPS0300

#### WITH GAS FLUSH

MODEL	SmartVac DZ-300G
ORDER CODE	VPS0300-GF

### 450mm SEALING BAR (TABLE MODEL)



#### SPECIFICATIONS

MODEL	SmartVac DZ-450
ELECTRICITY	220V, Single Phase
PUMP / SEAL POWER	0.9kW / 0.8kW
DIMENSIONS	560 x 520 x 460mm high
CHAMBER SIZE	460 x 450 x 220mm deep
SEALING BAR	(2x) 450 x 10mm
WEIGHT	68kg
OUTPUT	2-4 times/min

ORDER CODE	VPS0450
------------	---------

### 260mm SEALING BAR (TABLE MODEL)



#### SPECIFICATIONS

MODEL	SmartVac DZ-260C
ELECTRICITY	220V, Single Phase
PUMP / SEAL POWER	0.12kW / 0.4kW
DIMENSIONS	480 x 330 x 320mm high
CHAMBER SIZE	320 x 270 x 57mm deep
SEALING BAR	260 x 8mm
WEIGHT	36kg
OUTPUT	2-4 times/min

ORDER CODE	VPS0260
------------	---------

## FEATURES

- This product finishes continuous carrying, sealing and printing in one operation
- Fitted with an electronic constant temperature control system
- Fitted with a stepless speed adjusting transmission mechanism
- Pure aluminum turbine box, polyoxymethylene gear and a high-power 80W copper core motor ensures high power, stable performance, low noise and high efficiency
- Fitted with an emergency stop switch to stop quickly in case of emergency
- Fitted with a pure copper heating block - evenly heated and durable
- The machine is supplied with an embossing wheel and a printing wheel as standard
- The sealing width is 6-12mm, which can be adjusted manually
- Fitted with non-slip feet
- The Vertical continuous sealer allows you to package and seal liquids as well



## VERTICAL SPECIFICATIONS

MODEL	SmartVac FR-880-LW
ELECTRICITY	0.85kW, 220V, Single Phase
DIMENSIONS	860 x 420 x 350mm high
WEIGHT	20kg
SEAL WIDTH	6 ~ 12mm
OUTPUT	0 ~ 12m/min
TEMPERATURE RANGE	0 ~ 300°C
MAX LOAD	5kg



ORDER CODE **SMS0880-LW**

## HORIZONTAL SPECIFICATIONS

MODEL	SmartVac FR-880
ELECTRICITY	0.85kW, 220V, Single Phase
DIMENSIONS	860 x 420 x 350mm high
WEIGHT	19kg
SEAL WIDTH	6 ~ 12mm
OUTPUT	0 ~ 12m/min
TEMPERATURE RANGE	0 ~ 300°C
MAX LOAD	5kg



ORDER CODE **SMS0880**



**VERTICAL SEALER**  
IDEAL FOR SEALING LIQUIDS



**HORIZONTAL SEALER**  
IDEAL FOR SEALING DRY FOODS



# HAND PRESS IMPULSE SEALERS



### FEATURES

- Body is manufactured from heavy duty painted steel
- Fitted with a timer control and a LED indicator light
- No pre-heating required
- Seals a variety of materials
- Light weight and portable
- Fitted with (4x) non-slip feet

## 400mm SEALING BAR

### SPECIFICATIONS

MODEL SmartVac PFS-400i  
 ELECTRICITY 0.6kW, 220V, Single Phase  
 DIMENSIONS 550 x 85 x 180mm high  
 WEIGHT 2.8kg  
 SEALING BAR 400mm  
 HEATING TIME 0.2 ~ 1.5sec

ORDER CODE **HSM1400**



## 300mm SEALING BAR

### SPECIFICATIONS

MODEL SmartVac PFS-300i  
 ELECTRICITY 0.4kW, 220V, Single Phase  
 DIMENSIONS 450 x 85 x 180mm high  
 WEIGHT 2.5kg  
 SEALING BAR 300mm  
 HEATING TIME 0.2 ~ 1.5sec

ORDER CODE **HSM1300**



## 200mm SEALING BAR

### SPECIFICATIONS

MODEL SmartVac PFS-200i  
 ELECTRICITY 0.3W, 220V, Single Phase  
 DIMENSIONS 320 x 80 x 150mm high  
 WEIGHT 1.8kg  
 SEALING BAR 200mm  
 HEATING TIME 0.2 ~ 1.5sec

ORDER CODE **HSM1200**



# WRAPPING MACHINE



### FEATURES

- Body is manufactured from stainless steel
- Light weight and portable
- Fitted with (4x) non-slip feet

## 430mm

### SPECIFICATIONS

MODEL SmartVac HWM-430  
 ELECTRICITY 0.75kW, 220V, Single Phase  
 DIMENSIONS 430 x 660 x 155mm high  
 WEIGHT 5kg  
 MAX ROLL SIZE 380mm

ORDER CODE **WMS0430**



## 550mm

### SPECIFICATIONS

MODEL SmartVac HWM-550  
 ELECTRICITY 0.75kW, 220V, Single Phase  
 DIMENSIONS 550 x 660 x 155mm high  
 WEIGHT 7kg  
 MAX ROLL SIZE 500mm

ORDER CODE **WMS0550**



# SmartChef

## PRESSURE FRYERS



SmartChef



## SECTION INDEX

Boiling tables (Gas) .....	29
Brat pans .....	38-39
Char grillers (Gas) .....	30
Charcoal ovens .....	76-77
Chip dumps .....	46
Combi steam ovens	
• Electricity .....	60-64, 67
• Gas .....	65
Cone bakers .....	53
Contact grills .....	48
Convection ovens .....	66, 68-69, 74
Conveyor toasters .....	50
Cooking ranges	
• Electric (Full) .....	36-37
• Gas (Full) .....	28
• Gas (Electric oven) .....	34-35
Crepe makers .....	54
Deck ovens	
• Electric .....	78, 84-86
• Gas .....	87
Dough proofers .....	75
Flat top griddles	
• Electric .....	47
• Gas .....	31, 47
Fryers	
• Electric (Floor standing) .....	42
• Electric (Table model) .....	45
• Gas (Floor standing) .....	43
• Pressure .....	44
Induction cookers .....	41
Microwave ovens .....	52
Oven grids & pans .....	70, 88
Ovens	
• Charcoal ovens .....	76-77
• Convection ovens .....	66, 68-69, 74
• Combi steam ovens .....	60-65, 67
• Deck ovens .....	78, 84-87
• Pastry ovens .....	66, 68-69, 74
• Pizza ovens .....	78-82
Proofers .....	75
Radiant grillers (Gas) .....	30
Rice cookers .....	52
Salamanders .....	51
Sandwich toasters .....	49
Shawarma machines .....	40
Tilting pans .....	38-39
Toasters	
• Contact grills .....	48
• Conveyor .....	50
• Manual lift .....	50
• Sandwich .....	49
Waffle bakers	
• Belgian .....	55, 57
• Cone bakers .....	53
• Lolly (Waffle on a stick) .....	57
• Round .....	56, 58
Wok burners .....	40

## FEATURES

- Exterior body manufactured from Stainless steel
- Drip tray provided under burners to catch grease drippings
- Oven pilot with 100% safety shut off
- (1x) chrome oven rack per oven
- 3/4" NPT rear gas connection and regulator provided
- Enamel interior oven for easy cleaning
- Standing pilot for open top burners
- Multiple position oven rack guides
- Available in Natural and LPG models

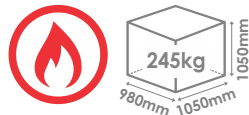

## 6 BURNER WITH OVEN

### SPECIFICATIONS

MODEL	CookRite ATO-6B
BURNER BTU	(6x) 23 000
OVEN BTU	27 000
TOTAL BTU	165 000
DIMENSIONS	915 x 815 x 910mm high (+ 51.5mm splashback)
WEIGHT	185kg
GRATE DIM	(6x) 300 x 300mm
OVEN INTERNAL DIM	670 x 660 x 355mm high
OVEN GRID SUPPLIED	(1x) 665 x 642mm
RUNNER SPACING	40mm
TEMPERATURE RANGE	80 ~ 280°C

**ORDER CODE** CR/ATO-6B

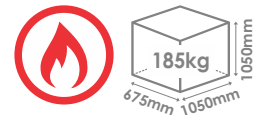

## 4 BURNER WITH OVEN

### SPECIFICATIONS

MODEL	CookRite ATO-4B
BURNER BTU	(4x) 23 000
OVEN BTU	24 000
TOTAL BTU	116 000
DIMENSIONS	610 x 815 x 910mm high (+ 51.5mm splashback)
WEIGHT	137kg
GRATE DIM	(4x) 300 x 300mm
OVEN INTERNAL DIM	510 x 660 x 355mm high
OVEN GRID SUPPLIED	(1x) 500 x 642mm
RUNNER SPACING	40mm
TEMPERATURE RANGE	80 ~ 280°C

**ORDER CODE** CR/ATO-4B

## ADDITIONAL OVEN GRIDS

DIMENSIONS	665 x 642mm
<b>ORDER CODE</b>	<b>CR/GRID-6B</b>

DIMENSIONS	500 x 642mm
<b>ORDER CODE</b>	<b>CR/GRID-4B</b>

# BOILING TABLES

## TABLE MODEL

### FEATURES

- Robust stainless steel exterior and interior
- Heavy duty burners with a standing pilot for open top burners
- Fitted with (4x) device levelling legs
- Fitted with a stainless steel full width crumb tray
- Heavy duty cast iron top grates



### 6 BURNER SPECIFICATIONS

MODEL	CookRite ATHP-36-6
BURNER BTU RATING	(6x) 25 000
TOTAL BTU RATING	150 000
DIMENSIONS	915 x 700 x 390mm high
WEIGHT	65kg
GRATE DIMENSIONS	(6x) 300 x 300mm

**ORDER CODE** CR/ATHP-36-3

### OPTIONAL STAND

DIMENSIONS	915 x 710 x 650mm high
ORDER CODE	CR/ATSE-2836



### 4 BURNER SPECIFICATIONS

MODEL	CookRite ATHP-24-4
BURNER BTU RATING	(4x) 25 000
TOTAL BTU RATING	100 000
DIMENSIONS	610 x 700 x 390mm high
WEIGHT	45kg
GRATE DIMENSIONS	(4x) 300 x 300mm

**ORDER CODE** CR/ATHP-24-4

### OPTIONAL STAND

DIMENSIONS	610 x 710 x 650mm high
ORDER CODE	CR/ATSE-2824



### 2 BURNER SPECIFICATIONS

MODEL	CookRite ATHP-12-2
BURNER BTU RATING	(2x) 25 000
TOTAL BTU RATING	50 000
DIMENSIONS	305 x 700 x 390mm high
WEIGHT	25kg
GRATE DIMENSIONS	(2x) 300 x 300mm

**ORDER CODE** CR/ATHP-12-2

# RADIANT / CHAR GRILLERS

## TABLE MODEL

### FEATURES

- Robust stainless steel exterior and interior
- Heavy duty, reversible cast-iron grates
- Top grates are multilevel / adjustable
- Fitted with (4x) device levelling legs



### OPTIONAL STAND

DIMENSIONS 915 x 710 x 650mm high  
 ORDER CODE CR/ATSE-2836

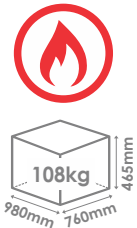

### 3 BURNER

#### SPECIFICATIONS

BURNER BTU RATING (3x) 35 000  
 TOTAL BTU RATING 105 000  
 DIMENSIONS 915 x 700 x 390mm high  
 WEIGHT 85kg  
 COOKING SURFACE 0.63m<sup>2</sup>

#### CHAR GRILLER

MODEL CookRite ATCB-36  
 ORDER CODE CR/ATCB-36

#### RADIANT GRILLER

MODEL CookRite ATRC-36  
 ORDER CODE CR/ATRC-36



### OPTIONAL STAND

DIMENSIONS 610 x 710 x 650mm high  
 ORDER CODE CR/ATSE-2824



### 2 BURNER

#### SPECIFICATIONS

BURNER BTU RATING (2x) 35 000  
 TOTAL BTU RATING 70 000  
 DIMENSIONS 610 x 700 x 390mm high  
 WEIGHT 65kg  
 COOKING SURFACE 0.41m<sup>2</sup>

#### CHAR GRILLER

MODEL CookRite ATCB-24  
 ORDER CODE CR/ATCB-24

#### RADIANT GRILLER

MODEL CookRite ATRC-24  
 ORDER CODE CR/ATRC-24

## STONES FOR CHAR GRILLERS

20kg GRILLING STONES  
 ORDER CODE GSB0001

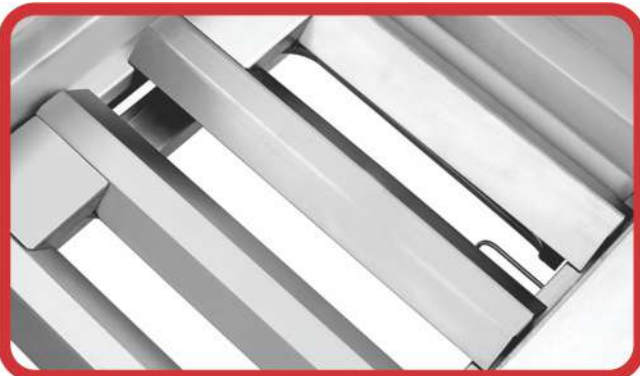

# FLAT TOP GRIDDLES

## TABLE MODEL

### FEATURES

- Robust stainless steel exterior and interior
- Heavy duty, 12mm thick polished griddle plate
- Supplied with a stainless steel grease drawer
- Fitted with (4x) device levelling legs



### 3 BURNER

#### SPECIFICATIONS

MODEL	CookRite ATMG-36
BURNER BTU RATING	(3x) 30 000
TOTAL BTU RATING	90 000
DIMENSIONS	915 x 700 x 390mm high
WEIGHT	105kg
COOKING SURFACE	0.63m <sup>2</sup>

ORDER CODE

CR/ATMG-36

#### OPTIONAL STAND

DIMENSIONS	915 x 710 x 650mm high
ORDER CODE	CR/ATSE-2836



### 2 BURNER

#### SPECIFICATIONS

MODEL	CookRite ATMG-24
BURNER BTU RATING	(2x) 30 000
TOTAL BTU RATING	60 000
DIMENSIONS	610 x 700 x 390mm high
WEIGHT	73kg
COOKING SURFACE	0.41m <sup>2</sup>

ORDER CODE

CR/ATMG-24

#### OPTIONAL STAND

DIMENSIONS	610 x 710 x 650mm high
ORDER CODE	CR/ATSE-2824



**FEATURES**

- Ships flat-packed
- Tools are included for easy assembly
- Sturdy, stainless steel top surface and under shelf
- Safety hemmed edge around the sides and back comes standard to keep equipment and other content from sliding off
- Added "H-shape" reinforced rib underneath the top surface makes it able to support more evenly distributed weight
- Adjustable under shelf and bullet feet provide additional storage space, as well as optimum stability



**1220mm SPECIFICATIONS**

MODEL CookRite ATSE-2848  
 DIMENSIONS 1220 x 710 x 650mm high  
 WEIGHT 29kg

ORDER CODE **CR/ATSE-2848**



**915mm SPECIFICATIONS**

MODEL CookRite ATSE-2836  
 DIMENSIONS 915 x 710 x 650mm high  
 WEIGHT 24kg

ORDER CODE **CR/ATSE-2836**



**610mm SPECIFICATIONS**

MODEL CookRite ATSE-2824  
 DIMENSIONS 610 x 710 x 650mm high  
 WEIGHT 18kg

ORDER CODE **CR/ATSE-2824**



**EASY TO ASSEMBLE**



**ADJUSTABLE FEET**



**DURABLE STAINLESS STEEL**



# CookRite



Create the ultimate chef's work station by combining CookRite cooking tops with CookRite chef bases.



\* FULL SPECS ON PAGE 139

# GAS COOKING RANGES WITH ELECTRIC CONVECTION OVEN



## FEATURES

- Powder-coated steel housing
- (3x) Large burners, (1x) small burner, (1x) wok burner
- Fitted with an electric igniter
- Cast iron grid over the burners
- Electric convection oven can accommodate up to (4x) GN 1/1 inserts
- The oven is fitted with (2x) fans without reverse function
- Thermostat 100°C to 275°C
- Additional upper 2.5 kW heating element for grilling
- Fitted with a timer for easier organisation of kitchen work
- Illuminated stainless-steel chamber
- Removable stainless-steel grid for GN trays
- Double-glazed door with free cooling to improve working safety
- Fitted with height-adjustable feet
- Available in 3 Phase and Single Phase units



## 5 BURNER - 3 PHASE

### SPECIFICATIONS

MODEL	TECNOEKA EKC96.3
BTU RATING	48 800
ELECTRICITY	5.2kW, 380V, 3 Phase + N
DIMENSIONS	900 x 600 x 900mm high
WEIGHT	74kg
INTERNAL OVEN DIM	665 x 410 x 350mm high
RUNNER SPACING	70mm
OVEN TEMP RANGE	100 ~ 275°C

**ORDER CODE** EKC96.3

## 5 BURNER - SINGLE PHASE

### SPECIFICATIONS

MODEL	TECNOEKA EKC96
BTU RATING	48 800
ELECTRICITY	2.6kW, 240V, Single Phase
DIMENSIONS	900 x 600 x 900mm high
WEIGHT	74kg
INTERNAL OVEN DIM	665 x 410 x 350mm high
RUNNER SPACING	70mm
OVEN TEMP RANGE	100 ~ 275°C

**ORDER CODE** EKC96

## OPTIONAL EXTRAS

**OVEN GRIDS**  
530 x 325mm

OGS0011

**FULL INSERT**  
GN 1/1 - 55mm deep

GNF8055



# GAS COOKING RANGES WITH ELECTRIC CONVECTION OVEN



## 6 BURNER WITH ELECTRIC CONVECTION OVEN & CABINET

### FEATURES

- Body and panelling manufactured of stainless steel
- Top grids manufactures from cast iron
- Each burner provides heat economy, operating independently from each other
- Fitted with a 1/1 GN electric convection oven and stainless steel neutral cabinet
- Oven controlled by thermostat against overheating
- Fitted with (4x) devise leveling legs
- Supplied with (1x) 1/1 GN oven grid



### SPECIFICATIONS

MODEL	Arisco GR732E/EO722/D711
BTU RATING	36 000
ELECTRICITY	3kW, 380V, 3 Phase + N
DIMENSIONS	1200 x 700 x 920mm high
WEIGHT	110kg
INTERNAL OVEN DIM	610 x 405 x 302mm high
RUNNER SPACING	48mm - 4 levels
INTERNAL CABINET DIM	355 x 537 x 425mm high
OVEN TEMP RANGE	50 ~ 320°C

**ORDER CODE**                      **ARI/6BG-EOC/700**

## 4 BURNER WITH ELECTRIC CONVECTION OVEN

### FEATURES

- Body and panelling manufactured of stainless steel
- Top grids manufactures from cast iron
- Each burner provides heat economy, operating independently from each other
- Fitted with a 1/1 GN electric convection oven
- Oven controlled by thermostat against overheating
- Fitted with (4x) devise leveling legs
- Supplied with (1x) 1/1 GN oven grid



### SPECIFICATIONS

MODEL	Arisco GR721S/EO722
BTU RATING	24 000
ELECTRICITY	3kW, 380V, 3 Phase + N
DIMENSIONS	800 x 700 x 920mm high
WEIGHT	97kg
INTERNAL OVEN DIM	610 x 405 x 302mm high
RUNNER SPACING	48mm - 4 levels
OVEN TEMP RANGE	50 ~ 320°C

**ORDER CODE**                      **ARI/4BG-EOC/700**

## OPTIONAL OVEN GRIDS

DIMENSIONS	530 x 325mm
ORDER CODE	OGS0011



## 4 PLATE WITH 1/1GN CONVECTION OVEN

### FEATURES

- Body and panelling manufactured of stainless steel
- Fitted with (4x) 220mm round plates
- Each plate provides heat economy, operating independently from each other
- Fitted with a 1/1 GN electric convection oven
- Controlled by thermostats against overheating
- Fitted with (4x) devise leveling legs
- Supplied with (1x) 1/1 GN oven grid



### SPECIFICATIONS

MODEL	Arisco ER722
ELECTRICITY	13.4kW, 380V, 3 Phase + N
DIMENSIONS	800 x 700 x 900mm high
WEIGHT	88kg
INTERNAL OVEN DIM	610 x 405 x 302mm high
RUNNER SPACING	48mm - 4 levels
OVEN TEMP RANGE	50 ~ 320°C

ORDER CODE                      **ARI/ER722**

## 4 PLATE WITH NEUTRAL CABINET

### FEATURES

- Body and panelling manufactured of stainless steel
- Fitted with (4x) 220mm round plates
- Each plate provides heat economy, operating independently from each other
- Controlled by thermostats against overheating
- Fitted with a stainless steel neutral cabinet
- Fitted with (4x) devise leveling legs



### SPECIFICATIONS

MODEL	Arisco ER721-S/D721
ELECTRICITY	10.4kW, 380V, 3 Phase + N
DIMENSIONS	800 x 700 x 900mm high
WEIGHT	53kg
INTERNAL CABINET DIM	710 x 537 x 425mm high

ORDER CODE                      **ARI/ER721S/D721**

## OPTIONAL OVEN GRIDS

DIMENSIONS	530 x 325mm
ORDER CODE	<b>OGS0011</b>



# ELECTRIC COOKING RANGES 900 SERIES

**arisco**®

## 4 PLATE WITH 2/1 GN CONVECTION OVEN

### FEATURES

- Body and panelling manufactured of stainless steel
- Fitted with (4x) 300 x 300mm square plates
- Each plate provides heat economy, operating independently from each other
- Fitted with a 2/1 GN electric convection oven
- Controlled by thermostats against overheating
- Fitted with (4x) devise leveling legs
- Supplied with (1x) 2/1 GN oven grid



### SPECIFICATIONS

MODEL	Arisco ER922
ELECTRICITY	22kW, 380V, 3 Phase + N
DIMENSIONS	850 x 900 x 900mm high
WEIGHT	149kg
INTERNAL OVEN DIM	610 x 615 x 302mm high
RUNNER SPACING	48mm - 4 levels
OVEN TEMP RANGE	50 ~ 300°C

ORDER CODE                      **ARI/ER922**

## 4 PLATE WITH NEUTRAL CABINET

### FEATURES

- Body and panelling manufactured of stainless steel
- Fitted with (4x) 300 x 300mm square plates
- Each plate provides heat economy, operating independently from each other
- Controlled by thermostats against overheating
- Fitted on a stainless steel neutral cabinet
- Fitted with (4x) devise leveling legs



### SPECIFICATIONS

MODEL	Arisco ER921
ELECTRICITY	16kW, 380V, 3 Phase + N
DIMENSIONS	850 x 900 x 900mm high
WEIGHT	108kg
INTERNAL CABINET DIM	825 x 790 x 425mm high

ORDER CODE                      **ARI/ER921**

## OPTIONAL OVEN GRIDS

DIMENSIONS	650 x 530mm
ORDER CODE	<b>OGS0021</b>

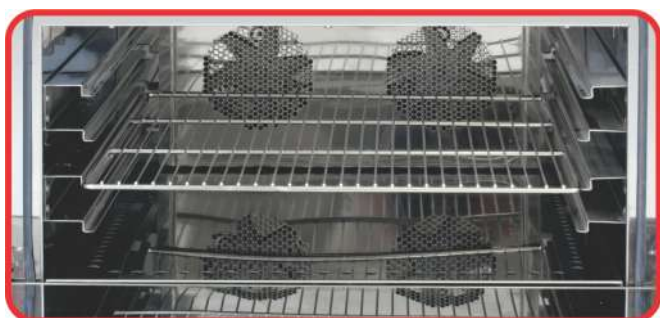

# TILTING / BRAT PANS ELECTRIC & GAS

**arisco**®

## FEATURES

- 304 stainless steel tank for easy cleaning
- Safety cutout switch - when tank is lifted burners/elements shut off
- Precise thermostatic temperature control
- Gas models are fitted with stainless steel burners and pilot light
- Fitted with (4x) devise leveling legs
- 10mm, 316L stainless steel base plate
- Easy to use analogue controls
- Fitted with water fill tap
- Manual tank lift mechanism
- Fitted with counterbalanced hinged lid



## 95 LITRE ELECTRIC

### SPECIFICATIONS

MODEL	Arisco EP922
ELECTRICITY	12kW, 380V, 3 Phase + N
DIMENSIONS	1000 x 900 x 900mm high
WEIGHT	163kg
CAPACITY	95L†
COOKING SURFACE	915 x 605mm - 0.55m <sup>2</sup>
TEMPERATURE RANGE	50 ~ 300°C

**ORDER CODE**                      **ARI/EP922**

## 95 LITRE GAS

### SPECIFICATIONS

MODEL	Arisco GP922
BTU RATING	71 655
DIMENSIONS	1000 x 900 x 900mm high
WEIGHT	163kg
CAPACITY	95L†
COOKING SURFACE	915 x 605mm - 0.55m <sup>2</sup>
TEMPERATURE RANGE	100 ~ 300°C

**ORDER CODE**                      **ARI/GP922**



# TILTING / BRAT PANS ELECTRIC

**Kromet**<sup>®</sup>



## FEATURES

- Robust stainless steel construction
- Pan tilt with manual tilting mechanism/wheel
- Manual lift lid
- Lid designed to prevent dripping
- Extremely durable and reliable product
- Fitted with (4x) device levelling plastic foot pieces

## 40 LITRE *ELECTRIC*

### SPECIFICATIONS

MODEL	Kromet 000.PE-025P
ELECTRICITY	5.4kW, 380V, 3 Phase + N
DIMENSIONS	700 x 600 x 850mm high
WEIGHT	72kg
CAPACITY	40Lt
COOKING SURFACE	0.25m <sup>2</sup>
TEMPERATURE RANGE	50 ~ 250°C

ORDER CODE

TPK0040



# DOUBLE BURNER WOK UNIT GAS



## FEATURES

- 1,5 mm thick work top is made of AISI 304 stainless steel
- High performance burners are made of cast iron
- Built-in Spice rack - (8x) GN 1/6 inserts can be used
- Supplied without inserts
- Heavy-duty upper cast iron rings are suitable for wok pots
- Fitted with water filling taps with push-pull system

## SPECIFICATIONS

MODEL	Crystal UMOP0101
BTU RATING	123 000
DIMENSIONS	1500 x 900 x 850mm high
WEIGHT	81kg
TEMPERATURE RANGE	80 ~ 280°C

## ORDER CODE

CRY-UMOP0101



## OPTIONAL INSERTS

GN 1/6 - 100mm deep

**GNS8100**

GN 1/6 - 65mm deep

**GNS8065**

GN 1/6 - Lid

**GNS8000**

# SHAWARMA MACHINES GAS



## FEATURES

- Machine body manufactured from stainless steel
- Fitted with a magnet safety valve
- Adjustable spear
- Sliding bottom housing of the spear allows shawarma meat to get closer to the burner
- Dual direction motor
- Hygienic and safe
- LPG or natural gas

## 4 BURNER SPECIFICATIONS

MODEL	Empero EMP.DN.151
ELECTRICITY	220V, Single Phase
BTU RATING	47 770
DIMENSIONS	750 x 620 x 1050mm high
WEIGHT	46kg
NUMBER OF BURNERS	4

## ORDER CODE

EMP.DN.151





# INDUCTION COOKERS TABLE MODEL

# SmartChef-i

## FEATURES

- Stainless steel body
- Touch control
- Timer (0 - 180min) on single plate only
- 10 temperature settings
- Black crystal glass hob
- LED display
- 10 power levels (500 - 3500W)
- Electronic overheating protection



## SINGLE

### SPECIFICATIONS

MODEL SmartChef-i BT-350K6-E  
ELECTRICITY 3.5kW, 230V, Single Phase  
DIMENSIONS 330 x 425 x 105mm high  
WEIGHT 5kg  
TEMPERATURE RANGE 60 ~ 240°C

ORDER CODE **ISC-BT-350K6-E**



## DOUBLE

### SPECIFICATIONS

MODEL SmartChef-i BT-700D3(T)  
ELECTRICITY (2x) 3.5kW, 230V, Single Phase  
DIMENSIONS 390 x 710 x 125mm high  
WEIGHT 14kg  
TEMPERATURE RANGE 60 ~ 240°C

ORDER CODE **ISC-BT-700D3(T)**



## WOK COOKER

### SPECIFICATIONS

MODEL SmartChef-i BT-350KCT-2-A  
ELECTRICITY 3.5kW, 230V, Single Phase  
DIMENSIONS 425 x 330 x 135mm high  
WEIGHT 6kg  
TEMPERATURE RANGE 60 ~ 240°C

ORDER CODE **ISC-BT-350KCT2A**



## WOK PAN

### SPECIFICATIONS

MODEL SmartChef-i SSWOK  
DIAMETER 360mm  
WEIGHT 3kg

ORDER CODE **ISC-SSWOK**

# ELECTRIC FRYERS FLOOR STANDING

# SmartChef

## FEATURES

- High quality stainless steel body
- High power for fast heating and recovery
- Replaceable individual heating elements
- Supplied with night covers
- Fitted with control and safety thermostat
- Even heat distribution
- Supplied with chrome plated wire baskets with insulated plastic hand grips
- Fitted with (4x) 150mm, height adjustable, device leveling legs



## 2 x 30L BINS

### SPECIFICATIONS

MODEL SmartChef E-DZ-800G  
 ELECTRICITY 36kW, 380V, 3 Phase + N  
 DIMENSIONS 800 x 825 x 900mm high  
 ( +260 mm splashback )  
 WEIGHT 260kg  
 TEMPERATURE RANGE 50 ~ 190°C  
 CAPACITY 2 x 30L  
 BASKETS INCLUDED (4x) 160 x 335 x 150mm deep  
 BASKET CAPACITY 7.5L

ORDER CODE **KB/E-DZ-800G**

## 4 x 15L BINS

### SPECIFICATIONS

MODEL SmartChef E-DZ-800G-2  
 ELECTRICITY 36kW, 380V, 3 Phase + N  
 DIMENSIONS 800 x 825 x 900mm high  
 ( +260 mm splashback )  
 WEIGHT 260kg  
 TEMPERATURE RANGE 50 ~ 190°C  
 CAPACITY 4 x 15L  
 BASKETS INCLUDED (4x) 160 x 335 x 150mm deep  
 BASKET CAPACITY 7.5L

ORDER CODE **KB/E-DZ-800G-2**



## 1 x 30L BIN

### SPECIFICATIONS

MODEL SmartChef E-DZ-400G  
 ELECTRICITY 18kW, 380V, 3 Phase + N  
 DIMENSIONS 400 x 825 x 900mm high  
 ( +260 mm splashback )  
 WEIGHT 195kg  
 TEMPERATURE RANGE 50 ~ 190°C  
 CAPACITY 30L  
 BASKETS INCLUDED (2x) 160 x 335 x 150mm deep  
 BASKET CAPACITY 7.5L

ORDER CODE **KB/E-DZ-400G**

## 2 x 15L BINS

### SPECIFICATIONS

MODEL SmartChef E-DZ-400G-2  
 ELECTRICITY 18kW, 380V, 3 Phase + N  
 DIMENSIONS 400 x 825 x 900mm high  
 ( +260 mm splashback )  
 WEIGHT 195kg  
 TEMPERATURE RANGE 50 ~ 190°C  
 CAPACITY 2 x 15L  
 BASKETS INCLUDED (2x) 160 x 335 x 150mm deep  
 BASKET CAPACITY 7.5L

ORDER CODE **KB/E-DZ-400G-2**

## OPTIONAL EXTRAS

**FRYER BASKET**  
 ORDER CODE **FBS0075**

**OIL RECEIVING BIN**  
 ORDER CODE **ORB0001**

**OIL FILTER STAND**  
 ORDER CODE **OFS0001**

**OIL FILTER BAGS**  
 ORDER CODE **OFB0001**

# GAS FRYERS FLOOR STANDING



### FEATURES

- Stainless steel exterior and interior
- Welded stainless steel tank
- Heavy duty burners with a standing flame and standby pilots
- High quality thermostat maintains select temperature automatically between 93°C - 200°C
- Oil cooling zone in the bottom of the tank captures food particles and extends oil life
- Safety valve with an automatic gas stabilizing function
- Self-reset high temperature limiting device
- Supplied with 2 nickel plated baskets with coated handles
- Supplied with wire mesh crumb screen and basket hanger
- Fitted with (4x) 150mm, height adjustable, device leveling legs

### 35L BIN

#### SPECIFICATIONS

MODEL	CookRite ATFS-75
BTU RATING	150 000
DIMENSIONS	536 x 765 x 920mm high ( +210 mm splashback )
WEIGHT	76kg
TEMPERATURE RANGE	93 ~ 200°C
CAPACITY	35Lt
BASKETS INCLUDED	(2x) 235 x 335 x 150mm deep
BASKET CAPACITY	12Lt

ORDER CODE **CR/ATFS-75**

#### ADDITIONAL BASKETS

DIMENSIONS	235 x 335 x 150mm deep
ORDER CODE	<b>FBS0012</b>



### 20L BIN

#### SPECIFICATIONS

MODEL	CookRite ATFS-40
BTU RATING	90 000
DIMENSIONS	400 x 765 x 920mm high ( +210 mm splashback )
WEIGHT	60kg
TEMPERATURE RANGE	93 ~ 200°C
CAPACITY	20Lt
BASKETS INCLUDED	(2x) 160 x 335 x 150mm deep
BASKET CAPACITY	7.5Lt

ORDER CODE **CR/ATFS-40**

#### ADDITIONAL BASKETS

DIMENSIONS	160 x 335 x 150mm deep
ORDER CODE	<b>FTS0075</b>

## OPTIONAL EXTRAS

**OIL RECEIVING BIN**  
ORDER CODE

ORB0001

**OIL FILTER STAND**  
ORDER CODE

OFS0001

**OIL FILTER BAGS**  
ORDER CODE

OFB0001



## FEATURES

- Body manufactured from 304 Stainless steel
- Built-in filtration system makes oil recycling easy and energy efficient
- Fitted with a pressure gauge
- Functions: electronic timing / automatic temperature and pressure control / exhausting and over-pressure protection
- Electronic control panel with 10 pre-programmed cooking functions
- Supplied with (1x) fryer baskets (Regular)
- Fitted with (4x) castors (2 lockable)

## 25 LITRE - FLOOR STANDING

### SPECIFICATIONS

MODEL	SmartChef YXD-25D
ELECTRICITY	13.5kW, 380V, 3 Phase + N
DIMENSIONS	470 x 920 x 1180mm high
WEIGHT	135kg
TEMPERATURE RANGE	60 ~ 200°C
OPERATING PRESSURE	12psi
CAPACITY	25Lt
BASKETS INCLUDED	(1x) 250 x 340 x 195mm deep
BASKET CAPACITY	16.5Lt

### ORDER CODE

**PFS-YXD-25D**



### OPTIONAL EXTRAS

250 x 340 x 195mm	<b>XPFS1000</b>
3 LAYER BASKET	<b>XPFS3000</b>
FILTER PAPER 20 PACK	<b>XPFS/0001</b>



## FEATURES

- Body manufactured from 304 Stainless steel
- Aluminum lid, rugged and lightweight, easy to open and close
- Manual temperature control and timer
- Quadruple explosion protection: Vent valve; pressure valve; silicone sealing ring; elastic beam
- Fitted with a pressure gauge
- Fitted with an oil drainage tap with a safety locking mechanism
- Supplied with fryer basket
- Fitted with non-slip feet

## 16 LITRE - TABLE MODEL

### SPECIFICATIONS

MODEL	SmartChef YXDT-16
ELECTRICITY	3kW, 230V, Single Phase
DIMENSIONS	440 x 570 x 520mm high
WEIGHT	21kg
TEMPERATURE RANGE	60 ~ 200°C
OPERATING PRESSURE	8psi
CAPACITY	16Lt
BASKETS INCLUDED	(1x) 738 Ø x 195mm deep
BASKET CAPACITY	8.5Lt

### ORDER CODE

**PFS-YXDT-16**



### ADDITIONAL BASKETS

738 Ø x 195mm	<b>XPFS0000</b>
---------------	-----------------



# ELECTRIC FRYERS TABLE MODEL

**SmartChef**

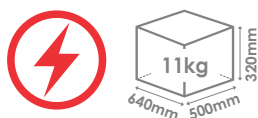

## FEATURES

- Removable element box
- 3kW element per pan for fast recovery
- Supplied with night cover and baskets
- Removable oil tank with special handles
- Fitted with safety thermostat
- Fitted with (4x) non-slip rubber feet

## 2 x 6Lt BINS

### SPECIFICATIONS

MODEL	SmartChef WF102
ELECTRICITY	(2x) 3kW, 230V, Single Phase
DIMENSIONS	590 x 440 x 285mm high
WEIGHT	9kg
TEMPERATURE RANGE	60°C ~ 200°C
CAPACITY	(2x) 6Lt
BASKETS INCLUDED	(2x) 200 x 215 x 100mm deep
BASKET CAPACITY	(2x) 4.3Lt

ORDER CODE

FTS2006

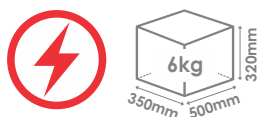

## 1 x 6Lt BIN

### SPECIFICATIONS

MODEL	SmartChef WF101
ELECTRICITY	3kW, 230V, Single Phase
DIMENSIONS	290 x 440 x 285mm high
WEIGHT	4kg
TEMPERATURE RANGE	60°C ~ 200°C
CAPACITY	6Lt
BASKETS INCLUDED	(1x) 200 x 215 x 100mm deep
BASKET CAPACITY	4.3Lt

ORDER CODE

FTS1006

## ADDITIONAL BASKET

DIMENSIONS	200 x 215 x 100mm deep
CAPACITY	4.3Lt

ORDER CODE

FBS0043



## CHIP DUMPS TABLE MODEL



### FEATURES

- Manufactured from stainless steel
- Heating element provides even heat distribution
- Ideal for keeping chips warm
- Fitted with (4x) non-slip rubber feet

### SPECIFICATIONS

MODEL	SmartChef HCW-620
ELECTRICITY	1kW, 230V, Single Phase
DIMENSIONS	345 x 605 x 550mm high
WEIGHT	7kg
TEMPERATURE RANGE	30 ~ 85°C

ORDER CODE

CDS1000



## CHIP DUMP / PACKING STATION



### FEATURES

- Manufactured from heavy-duty stainless steel
- Fitted with a removable drainboard and oil collecting pan to drain and collect excess oil
- Fitted with a multi-slot packaging shelf
- Infrared heating tubes provide heat to keep your fried foods hot, crisp, and ready to serve at all times
- Two warm light bulbs attached to the top illuminates the food station for improved display
- Separate switches provide simplified operation for controlling the heat and lights individually
- Fitted with 4 non-slip feet

### SPECIFICATIONS

MODEL	SmartChef HCW-8
ELECTRICITY	0.64kW, 220V, Single Phase
DIMENSIONS	800 x 700 x 650mm high
WEIGHT	31kg
TEMPERATURE RANGE	30°C ~ 85°C

ORDER CODE

CDS2000



## CHIP DUMP OPTIONAL EXTRAS

### STAINLESS STEEL CHIP BAGGING SCOOP

DIMENSIONS	190 x 200mm
ORDER CODE	CBS0001



## FLAT TOP GRIDDLES TABLE MODEL

# SmartChef



### ELECTRIC - 730mm

#### SPECIFICATIONS

MODEL	SmartChef HEG-820
ELECTRICITY	4.4kW, 230V, Single Phase
DIMENSIONS	730 x 470 x 240mm high
WEIGHT	34kg
COOKING SURFACE	728 x 400mm
TEMPERATURE RANGE	50°C ~ 300°C

ORDER CODE

FTS0730



#### FEATURES

- Strong stainless steel body with splash guard
- Large output capacity
- Thick steel plate for even heat distribution and heat retention
- Fat drainage drawer for convenience
- Thermostat controller
- Energy efficient
- Easy to use and clean-up
- Fitted with (4x) non-slip feet

### ELECTRIC - 550mm

#### SPECIFICATIONS

MODEL	SmartChef HEG-818
ELECTRICITY	3kW, 230V, Single Phase
DIMENSIONS	550 x 430 x 240mm high
WEIGHT	19kg
COOKING SURFACE	548 x 350mm
TEMPERATURE RANGE	50°C ~ 300°C

ORDER CODE

FTS0550



## FLAT TOP GRIDDLES

# omake

All Kitchen Equipments

#### FEATURES

- Electric and gas models available
- 6mm thick steel cooking surface
- 360°C Limit thermostat
- Easy to clean
- Body manufactured from 430 stainless steel
- Removable oil collection chamber
- Manual temperature control
- Modern ergonomic design



### ELECTRIC - 600mm

#### SPECIFICATIONS

MODEL	OMAKE IZG01-E11
ELECTRICITY	5.25kW, 220V, Single Phase
DIMENSIONS	600 x 480 x 270mm high
WEIGHT	30kg
COOKING SURFACE	400 x 585mm
TEMPERATURE RANGE	50 ~ 300°C

ORDER CODE

OMK-IZG01-E11



### GAS - 600mm

#### SPECIFICATIONS

MODEL	OMAKE IZG01-G11
BTU RATING	17 600 BTU/hr
DIMENSIONS	600 x 480 x 270mm high
WEIGHT	26kg
COOKING SURFACE	400 x 585mm
TEMPERATURE RANGE	50 ~ 300°C

ORDER CODE

OMK-IZG01-G11



## FEATURES

- Adjustable top plate for a variety of product thickness
- Heat resistant handle
- Available in full flat and full ribbed non-stick surface models
- Drip tray to catch excess fat
- Robust construction
- Fitted with (4x) non-slip feet



## NON-STICK FLAT PLATES

### SPECIFICATIONS

MODEL	SmartChef HEG-811EB
ELECTRICITY	2.2kW, 230V, Single Phase
DIMENSIONS	435 x 410 x 210mm high
WEIGHT	19kg
COOKING SURFACE	345 x 235mm
TEMPERATURE RANGE	50°C ~ 300°C

ORDER CODE                      CGS0002



## NON-STICK RIBBED PLATES

### SPECIFICATIONS

MODEL	SmartChef HEG-811E
ELECTRICITY	2.2kW, 230V, Single Phase
DIMENSIONS	435 x 410 x 210mm high
WEIGHT	19kg
COOKING SURFACE	345 x 235mm
TEMPERATURE RANGE	50°C ~ 300°C

ORDER CODE                      CGS1002





## FEATURES

- Robust construction
- Drip tray to catch excess fat
- Fitted with a heat resistant handle
- Adjustable top plate for a variety of product thickness
- Available in standard & non-stick plate models
- Fitted with (4x) non-slip feet



## STANDARD PLATES

### SPECIFICATIONS

MODEL	SmartChef HT-01
ELECTRICITY	2.2kW, 230V, Single Phase
DIMENSIONS	540 x 400 x 290mm high
WEIGHT	8kg
COOKING SURFACE	353 x 330mm
TEMPERATURE RANGE	50°C ~ 300°C

**ORDER CODE**                      **STS0009**



## NON-STICK PLATES

### SPECIFICATIONS

MODEL	SmartChef HT-01
ELECTRICITY	2.2kW, 230V, Single Phase
DIMENSIONS	540 x 400 x 290mm high
WEIGHT	8kg
COOKING SURFACE	353 x 330mm
TEMPERATURE RANGE	50°C ~ 300°C

**ORDER CODE**                      **STS1009**

## OPTIONAL EXTRAS

Teflon cover                              **TCT0001**





### FEATURES

- Stainless steel construction
- Various conveyor speed settings
- Standby / bread / roll settings available
- Perfect for self-service application
- Can be set to pass through or return to front operation
- Individual heat controls for top and bottom elements
- Fitted with (4x) device leveling legs

## 450 SLICE WIDE BELT

### SPECIFICATIONS

MODEL	SmartChef TT-450
ELECTRICITY	2.6kW, 230V, Single Phase
DIMENSIONS	470 x 420 x 400mm high
WEIGHT	18kg
CAPACITY	450 ~ 500 slices per hour

ORDER CODE **CTS0450**



## 300 SLICE

### SPECIFICATIONS

MODEL	SmartChef TT-300
ELECTRICITY	1.94kW, 230V, Single Phase
DIMENSIONS	350 x 420 x 400mm high
WEIGHT	14kg
CAPACITY	300 ~ 350 slices per hour

ORDER CODE **CTS0300**

# 6 SLICE TOASTERS



### FEATURES

- Stainless steel construction
- Fitted with a timer
- 3 or 6 slot operation can be chosen
- Fitted with (4x) non-slip feet

### SPECIFICATIONS

MODEL	SmartChef HET-6
ELECTRICITY	3.2kW, 230V, Single Phase
DIMENSIONS	460 x 210 x 225mm high
WEIGHT	7kg
CAPACITY	3/6 slices

ORDER CODE **TLS0006**

# SALAMANDERS GAS



### FEATURES

- High quality stainless steel structure
- Corrosion resistant and easy to clean
- Thick steel plate for even heat distribution and heat retention
- 4 Position adjustable shelf
- Fat drainage drawer for convenience
- Thermostat controller
- (2x) 21,500 BTU high efficiency ceramic infrared burners and standby pilots
- Energy efficient
- Easy to use and clean
- Fitted with (4x) non-slip feet



### SPECIFICATIONS

MODEL	CookRite ATSB-36
TOTAL BTU RATING	43 000
DIMENSIONS	914 x 457 x 440mm high
WEIGHT	65kg
RUNNER SPACING	95mm
SHELF DIMENSIONS	710 x 356mm

**ORDER CODE** **CR/ATSB-36**

# SALAMANDERS ELECTRIC



### SPECIFICATIONS

ELECTRICITY	4.4kW, 380V, 3 Phase + N
DIMENSIONS	880 x 370 x 380mm high
WEIGHT	28kg
TEMPERATURE RANGE	30°C ~ 90°C
RUNNER SPACING	70mm

### LEVER LIFT GRID

MODEL	RM Gastro SE70M
SHELF DIMENSIONS	645 x 300mm

**ORDER CODE** **RMG/SE70M**

### REMOVABLE GRID

MODEL	RM Gastro SE70
SHELF DIMENSIONS	710 x 300mm

**ORDER CODE** **RMG/SE70**

### FEATURES

- Inner and outer casing manufactured from stainless steel
- Rear panel can be removed to have pass through hatch
- Fitted with 2 sets of individually controlled incolloy elements
- Model SE70M has 4 pre-set positions for adjustable grid
- Model SE70 has 3 pre-set positions for removable grid
- Fitted with (4x) non-slip plastic feet

### OPTIONAL WALL MOUNTING PLATE

**ORDER CODE** **RMG/DSE-47**

## ELECTRIC RICE COOKER

**SmartChef**



### FEATURES

- Painted steel exterior pot fitted with cool-touch plastic handles
- Removable interior cooking pot manufactured from high quality aluminium
- Stainless steel lid with cool-touch plastic handle
- Keep-warm function keeps food fresh before serving
- Cooking and keep-warm indicator lights
- Fitted with (3x) plastic feet
- Supplied with a food grade plastic rice spoon

### SPECIFICATIONS

MODEL	SmartChef ERC-10L
ELECTRICITY	1.6kW, 220V, Single Phase
DIMENSIONS	710 Ø x 325mm high
WEIGHT	5kg
CAPACITY	10Lt

ORDER CODE

RCS0010



## MICROWAVE OVEN



### FEATURES

- All stainless steel exterior and interior
- Audible alarm when timed cycle is complete
- Includes interior light
- Large easy to grip polished handle with durable interlock system
- Reinforced flexible door latch to reduce breakage
- Digital touch pad controls
- LED display
- 3 stage cooking capabilities
- Fitted with (4x) non-slip rubber feet



### SPECIFICATIONS

MODEL	General Wave GEW1050E
ELECTRICITY	1kW, 220V, Single Phase
DIMENSIONS	508 x 356 x 305mm high
WEIGHT	16kg
CAPACITY	28Lt

ORDER CODE

MWG1001



## OPTIONAL MICROWAVE WALL BRACKET

DIMENSIONS	600 x 400mm
ORDER CODE	WBM0001

## FEATURES

- Machine body manufactured from stainless steel
- Fitted with a timer
- Easy to clean
- Fitted with (4x) non-slip feet
- Baking plates manufactured from Teflon coated cast iron
- Thermostat controlled
- Spiral metal handles. Isolated to prevent burning
- Cone roller moulds included



## DOUBLE PLATE SPECIFICATIONS

**MODEL** SmartChef HCB-2  
**ELECTRICITY** 2.4kW, 230V, Single Phase  
**DIMENSIONS** 500 x 360 x 270mm high  
**WEIGHT** 11kg  
**BAKING SURFACE** (2x) 210mm Ø  
**TEMPERATURE RANGE** 50 ~ 300°C

**ORDER CODE**

**CBS1002**



## SINGLE PLATE SPECIFICATIONS

**MODEL** SmartChef HCB-1  
**ELECTRICITY** 1.2kW, 230V, Single Phase  
**DIMENSIONS** 250 x 360 x 270mm high  
**WEIGHT** 6.4kg  
**BAKING SURFACE** 210mm Ø  
**TEMPERATURE RANGE** 50 ~ 300°C

**ORDER CODE**

**CBS1001**



# CREPE MAKERS



## FEATURES

- Body manufactured from 430 stainless steel
- Teflon coated cast-iron cooking surface
- Stainless steel heating element
- Digital temperature control and timer for precise temperature and cooking time
- Easy to clean

## SPECIFICATIONS

MODEL	OMAKE KRP01-E15
ELECTRICITY	3kW, 220V, Single Phase
DIMENSIONS	500 x 460 x 270mm high
WEIGHT	19kg
BAKING SURFACE	400mm Ø
TEMPERATURE RANGE	90 ~ 250°C

ORDER CODE

OMK-KRP01-E15

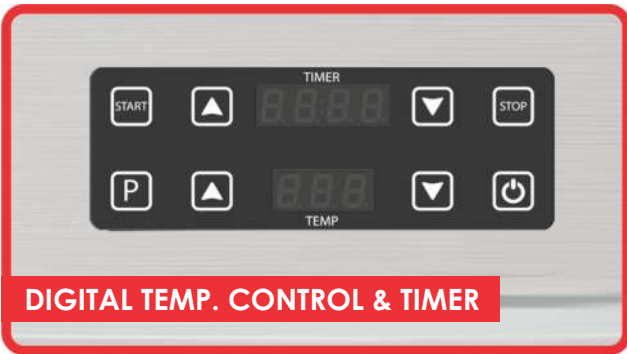

# SQUARE BELGIAN WAFFLE BAKERS HEAVY DUTY

## FEATURES

- Teflon coated aluminium injection body
- Teflon coated aluminium injection mould (*Belgian as standard*)
- Stainless steel heating elements
- Modern ergonomic design
- Available in single and double models
- 430 Stainless steel base
- Additional easy interchangeable mould shapes available
- Easy to clean
- Fitted with (4x) non-slip feet
- Manual and digital control models available



## DOUBLE SPECIFICATIONS

ELECTRICITY	5kW, 230V, Single Phase
DIMENSIONS	560 x 450 x 270mm high
WEIGHT	24kg
BAKING SURFACE	(2x) 220 x 220mm
TEMPERATURE RANGE	50 ~ 250°C

## DIGITAL CONTROL

MODEL	OMAKE WFL21-E25-2101
ORDER CODE	OMK-WFL21-E25

## MANUAL CONTROL

MODEL	OMAKE WFL21-E21-2101
ORDER CODE	OMK-WFL21-E21



## SINGLE SPECIFICATIONS

ELECTRICITY	2.5kW, 230V, Single Phase
DIMENSIONS	270 x 450 x 270mm high
WEIGHT	13kg
BAKING SURFACE	220 x 220mm
TEMPERATURE RANGE	50 ~ 250°C

## DIGITAL CONTROL

MODEL	OMAKE WFL21-E15-2101
ORDER CODE	OMK-WFL21-E15

## MANUAL CONTROL

MODEL	OMAKE WFL21-E11-2101
ORDER CODE	OMK-WFL21-E11

## ADDITIONAL INTERCHANGEABLE MOLDS



**CLASSIC**

ORDER CODE  
OMK-WFL21-2102



**MINI SQUARE**

ORDER CODE  
OMK-WFL21-2103



**HEART SHAPE**

ORDER CODE  
OMK-WFL21-2107



**WAFFLE LOLLY**

ORDER CODE  
OMK-WFL21-2111



**CONE PLATE**

ORDER CODE  
OMK-WFL21-2109

# ROUND BELGIAN WAFFLE BAKERS ROTATING

## FEATURES

- Teflon coated aluminium injection body
- Teflon coated aluminium injection mould (Belgian round as standard)
- Stainless steel heating elements
- Digital temperature control and timer ensures constant baking results
- Available in single and double models
- 430 Stainless steel base
- Baking mechanism rotates 180°
- Modern ergonomic design
- Easy to clean
- Fitted with (4x) non-slip feet



## DOUBLE - DIGITAL CONTROL

### SPECIFICATIONS

MODEL	OMAKE WFL02-E25-0101
ELECTRICITY	5kW, 230V, Single Phase
DIMENSIONS	560 x 450 x 270mm high
WEIGHT	24kg
BAKING SURFACE	(2x) 180mm Ø
TEMPERATURE RANGE	50 ~ 300°C

ORDER CODE **OMK-WFL02-E25**



## SINGLE - DIGITAL CONTROL

### SPECIFICATIONS

MODEL	OMAKE WFL02-E15-0101
ELECTRICITY	2.5kW, 230V, Single Phase
DIMENSIONS	270 x 450 x 270mm high
WEIGHT	13kg
BAKING SURFACE	180mm Ø
TEMPERATURE RANGE	50 ~ 300°C

ORDER CODE **OMK-WFL02-E15**



HEAD ROTATES 180° FOR OPTIMUM BAKING



DIGITAL TEMPERATURE CONTROL & TIMER



# WAFFLE BAKERS SNACK

## FEATURES

- Machine body manufactured from stainless steel
- The handles are manufactured from heat-resistant material
- Fitted with a timer
- A removable tray around the bottom of the work surface is used to collect excess dough for easy cleaning
- Baking plates manufactured from heavy duty cast iron
- Thermostat controlled
- Fitted with (4x) non-slip feet



### BELGIAN - DOUBLE

#### SPECIFICATIONS

MODEL	SmartChef HWB-2S
ELECTRICITY	3.2kW, 230V, Single Phase
DIMENSIONS	570 x 380 x 250mm high
WEIGHT	20.5kg
BAKING SURFACE	(2x) 220 x 220mm
TEMPERATURE RANGE	50 ~ 300°C

ORDER CODE                      **WBS0002**



### BELGIAN - SINGLE

#### SPECIFICATIONS

MODEL	SmartChef HWB-1S
ELECTRICITY	1.6kW, 230V, Single Phase
DIMENSIONS	290 x 330 x 250mm high
WEIGHT	7.5kg
BAKING SURFACE	220 x 220mm
TEMPERATURE RANGE	50 ~ 300°C

ORDER CODE                      **WBS0001**



### WAFFLE LOLLY WAFFLE ON A STICK

#### SPECIFICATIONS

MODEL	SmartChef HX-2208
ELECTRICITY	1.7kW, 230V, Single Phase
DIMENSIONS	330 x 365 x 235mm high
WEIGHT	10kg
CAPACITY	4 Rows
SINGLE WAFFLE SIZE	225 x 60 x 15mm
TEMPERATURE RANGE	50 ~ 300°C

ORDER CODE                      **WBS2001**



# ROUND WAFFLE BAKERS SNACK

**SmartChef**

## FEATURES

- Machine body manufactured from stainless steel
- Fitted with heat-insulated handles
- Fitted with a timer
- Fitted with (4x) non-slip feet
- Baking plates manufactured from non-stick, heavy duty, cast iron
- Thermostat controlled
- A removable tray around the bottom of the work surface is used to collect excess dough for easy cleaning



## DOUBLE SPECIFICATIONS

MODEL SmartChef HWB-2  
ELECTRICITY 2kW, 230V, Single Phase  
DIMENSIONS 500 x 350 x 260mm high  
WEIGHT 11kg  
BAKING SURFACE (2x) 170mm Ø  
TEMPERATURE RANGE 50 ~ 300°C

ORDER CODE WBS1002



## SINGLE SPECIFICATIONS

MODEL SmartChef HWB-1  
ELECTRICITY 1kW, 230V, Single Phase  
DIMENSIONS 250 x 350 x 260mm high  
WEIGHT 6kg  
BAKING SURFACE 170mm Ø  
TEMPERATURE RANGE 50 ~ 300°C

ORDER CODE WBS1001





# COMBI STEAMERS & CONVECTION OVENS





**FEATURES**

- Patented fan guard system *Airflowlogic™*
- Patented system for direct steam *Humilogic™*
- Patented system for cooking chamber drying *Drylogic™*
- Outer casing manufactured from AISI 304 stainless steel
- Cooking chamber is manufactured from 1mm - thick, moulded, AISI 304 18/10 stainless steel with fully rounded edges
- Cooking chamber lighting via LED Bar fitted into the door
- Door is right hand hinged with adjustable door hinges and handle catch
- 10 Levels of direct steam controlled by a touch control panel situated on the right hand side of the door
- Fitted with quick selection knob for the touch screen
- The side supports and drip tray can easily be removed for cleaning
- Fitted with 4 bidirectional fan motors for even heat distribution
- 500 Programmable recipes
- Delayed start function up to 23 hours and 59 minutes
- Supplied with multipoint core prob
- Supplied without trays and grids
- IPX5 protection rating against water
- 42 Language settings for the control panel
- Humidity management software installed
- Automatic washing system integrated
- Supplied without chemicals

\*\* It is recommend that all combi steamers be installed with water treatment system



**20 PAN GASTRONOMY**

**SPECIFICATIONS**

MODEL	EKA MKF 2011 TS
ELECTRICITY	31kW, 380V, 3 Phase + N
DIMENSIONS	930 x 1035 x 1900mm high
WEIGHT	247kg
CHAMBER DIMENSIONS	710 x 551 x 1440mm high
TEMPERATURE RANGE	30 ~ 270°C
NUMBER OF PROGRAMS	500
PROGRAMMABLE COOKING STEPS	10
PRE-HEATING TEMPERATURE	180°C

**ORDER CODE**

**MKF2011TS**

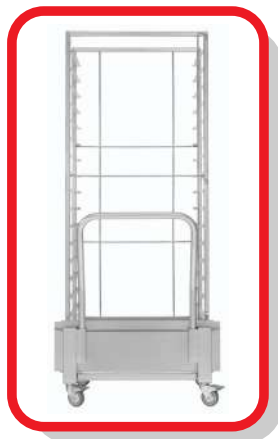

**Supplied with 20 pan gastronomy trolley with handle**

CAPACITY	(20x) 1/1GN Pans
RUNNER SPACING	66mm
<b>ORDER CODE</b>	<b>EKF-EKCR20TC</b>

**Convert your oven to a 16 tray baking oven by changing trolleys**

CAPACITY	(16x) 600 x 400 baking trays
RUNNER SPACING	80mm
<b>ORDER CODE</b>	<b>EKF-EKCR16TC</b>

**OPTIONAL EXTRAS (FULL SPECS • PAGE 70 - 71)**

**INSERTS**

- 1/1 GN PAN - 55mm
- 1/1 GN PAN - 55mm (perforated)
- 1/1 GN PAN - 40mm
- 1/1 GN PAN - 40mm (perforated)

- GNF8055**
- GNF8055.P**
- GNF8040**
- GNF8040.P**

**GRIDS**

- 1/1 GN GRID

**OGS0011**

**BAKING TRAYS**

- 600 x 400 x 30mm

**BTA0064**

**CLEANING**

- CLEANING DETERGENT

**MKF-MKDET**



**FEATURES**

- Outer casing manufactured from AISI 304 stainless steel
- Cooking chamber is manufactured from 1mm - thick, moulded, AISI 304 18/10 stainless steel with fully rounded edges
- Cooking chamber lighting via LED Bar fitted into the door
- Door is right hand hinged with adjustable door hinges and handle catch
- The side supports and drip tray can easily be removed for cleaning
- Manual hand spray/wash can be fitted
- 5 Levels of direct steam controlled by a manual control panel situated on the right hand side of the door
- Fitted with a condensate collection bowl, with drain on door
- Fitted with 4 bidirectional fan motors for even heat distribution
- IPX4 protection rating against water
- Timer for cooking from 10 to 120 minutes / infinity
- Supplied without stand
- Supplied without trays and grids
- Supplied without chemicals

\*\* It is recommend that all combi steamers be installed with water treatment system

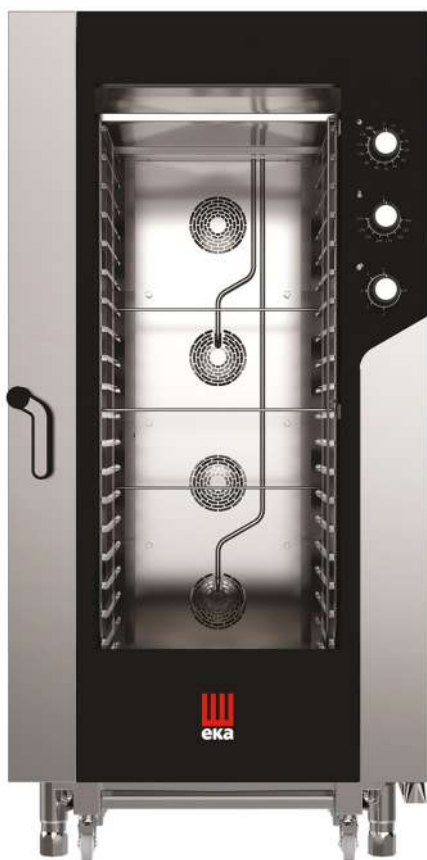

**20 PAN GASTRONOMY**

**SPECIFICATIONS**

MODEL	EKA MKF 2011 S
ELECTRICITY	31kW, 380V, 3 Phase + N
DIMENSIONS	930 x 1041 x 1900mm high
WEIGHT	247kg
CHAMBER DIMENSIONS	710 x 551 x 1440mm high
TEMPERATURE RANGE	30 ~ 270°C
PRE-HEATING TEMPERATURE	180°C

**ORDER CODE**

**MKF2011S**



**Supplied with 20 pan gastronomy trolley with handle**

CAPACITY	(20x) 1/1GN Pans
RUNNER SPACING	66mm
<b>ORDER CODE</b>	<b>EKF-EKCR20TC</b>

**Convert your oven to a 16 tray baking oven by changing trolleys**

CAPACITY	(16x) 600 x 400 baking trays
RUNNER SPACING	80mm
<b>ORDER CODE</b>	<b>EKF-EKCR16TC</b>

**OPTIONAL EXTRAS (FULL SPECS • PAGE 70 - 71)**

**INSERTS**

- 1/1 GN PAN - 55mm
- 1/1 GN PAN - 55mm (perforated)
- 1/1 GN PAN - 40mm
- 1/1 GN PAN - 40mm (perforated)

- GNF8055**
- GNF8055.P**
- GNF8040**
- GNF8040.P**

**GRIDS**

- 1/1 GN GRID

**OGS0011**

**BAKING TRAYS**

- 600 x 400 x 30mm

**BTA0064**

**CLEANING**

- MANUAL SPAY KIT

**EKF-EKKD**



**FEATURES**

- Patented technology Airflowlogic™ / Humilogic™ / Drylogic™
- Outer casing manufactured from AISI 304 stainless steel
- Cooking chamber is manufactured from 1mm - thick, moulded, AISI 304 18/10 stainless steel with fully rounded edges
- Cooking chamber lighting via LED Bar fitted into the door
- Door is right hand hinged with adjustable door hinges and handle catch
- The side supports and drip tray can easily be removed for cleaning
- 10 Levels of direct steam controlled by a touch control panel situated on the right hand side of the door
- IPX5 protection rating against water
- 42 Language settings for the control panel
- Humidity management software installed
- Automatic washing system integrated
- Stand, trays and grids NOT supplied
- Fitted with quick selection knob for the touch screen
- 500 Programmable recipes
- Fitted with a Wi-fi communication system
- Delayed start function up to 23 hours and 59 minutes
- Multipoint core probe included

\*\* It is recommend that all combi steamers be installed with water treatment system



**11 PAN GASTRONOMY**

**SPECIFICATIONS**

MODEL	EKA MKF 1111 TS
ELECTRICITY	15.4kW, 380V, 3 Phase + N
DIMENSIONS	730 x 850 x 1130mm high
WEIGHT	114kg
CAPACITY	(11x) 1/1 GN pans
RUNNER SPACING	68mm
NUMBER OF FANS	(2x) bidirectional
TEMPERATURE RANGE	30 ~ 270°C
NO. OF PROGRAMS	500
PROG. COOKING STEPS	10
PRE-HEAT TEMPERATURE	180°C



**ORDER CODE** MKF1111TS

**7 PAN GASTRONOMY**

**SPECIFICATIONS**

MODEL	EKA MKF 711 TS
ELECTRICITY	11.4kW, 380V, 3 Phase + N
DIMENSIONS	730 x 850 x 850mm high
WEIGHT	96kg
CAPACITY	(7x) 1/1 GN pans
RUNNER SPACING	68mm
NUMBER OF FANS	(2x) bidirectional
TEMPERATURE RANGE	30 ~ 270°C
NO. OF PROGRAMS	500
PROG. COOKING STEPS	10
PRE-HEAT TEMPERATURE	180°C



**ORDER CODE** MKF711TS

**OPTIONAL EXTRAS (FULL SPECS • PAGE 70 - 71)**

**INSERTS**

1/1 GN PAN - 55mm	<b>GNF8055</b>
1/1 GN PAN - 55mm (perforated)	<b>GNF8055.P</b>
1/1 GN PAN - 40mm	<b>GNF8040</b>
1/1 GN PAN - 40mm (perforated)	<b>GNF8040.P</b>

**GRIDS**

1/1 GN GRID	<b>OGS0011</b>
-------------	----------------

**STANDS**

Stand for MKF1111TS	<b>MKF-MKTS1111-L</b>
Stand for MKF711TS	<b>MKF-MKTS711-L</b>

**CLEANING**

CLEANING DETERGENT	<b>MKF-MKDET</b>
--------------------	------------------



**FEATURES**

- Outer casing manufactured from stainless steel
- Cooking chamber is manufactured from 1mm - thick, moulded, AISI 304 18/10 stainless steel with fully rounded edges
- Cooking chamber lighting via LED Bar fitted into the door
- Door is right hand hinged with adjustable door hinges and handle catch
- The side supports and drip tray can easily be removed for cleaning
- Manual hand spray/wash can be fitted
- 5 Levels of direct steam controlled by a manual control panel situated on the right hand side of the door
- IPX4 protection rating against water
- Timer for cooking from 10 to 120 minutes / infinity
- Supplied without trays and grids
- Fitted with a condensate collection bowl, with drain on door
- Supplied without stand
- Fitted with 2 bidirectional fan motors for even heat distribution

\*\* It is recommend that all combi steamers be installed with water treatment system

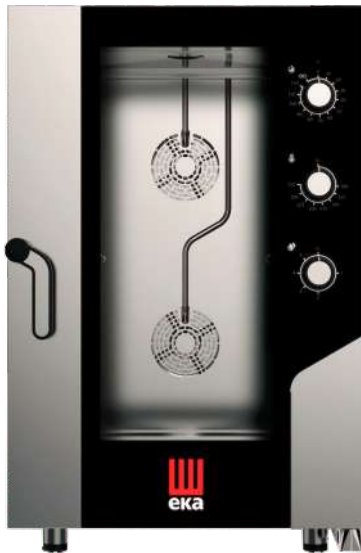

**11 PAN GASTRONOMY**

**SPECIFICATIONS**

MODEL	EKA MKF 1111 S
ELECTRICITY	15.4kW, 380V, 3 Phase + N
DIMENSIONS	730 x 855 x 1130mm high
WEIGHT	114kg
CAPACITY	(11x) 1/1 GN pans
RUNNER SPACING	68mm
NUMBER OF FANS	(2x) bidirectional
TEMPERATURE RANGE	30 ~ 270 °C

ORDER CODE **MKF1111S**



**7 PAN GASTRONOMY**

**SPECIFICATIONS**

MODEL	EKA MKF 711 S
ELECTRICITY	10.4kW, 380V, 3 Phase + N
DIMENSIONS	730 x 855 x 850mm high
WEIGHT	96kg
CAPACITY	(7x) 1/1 GN pans
RUNNER SPACING	68mm
NUMBER OF FANS	(2x) bidirectional
TEMPERATURE RANGE	30 ~ 270 °C

ORDER CODE **MKF711S**



**OPTIONAL EXTRAS (FULL SPECS • PAGE 70 - 71)**

**INSERTS**

1/1 GN PAN - 55mm	<b>GNF8055</b>
1/1 GN PAN - 55mm (perforated)	<b>GNF8055.P</b>
1/1 GN PAN - 40mm	<b>GNF8040</b>
1/1 GN PAN - 40mm (perforated)	<b>GNF8040.P</b>

**GRIDS**

1/1 GN GRID	<b>OGS0011</b>
-------------	----------------

**STANDS**

Stand for MKF1111TS	<b>MKF-MKTS1111-L</b>
Stand for MKF711TS	<b>MKF-MKTS711-L</b>

**CLEANING**

MANUAL SPRAY KIT	<b>EKF-EKGD</b>
------------------	-----------------



**FEATURES**

- Outer casing manufactured from stainless steel
- Cooking chamber is manufactured from 1mm - thick, moulded, AISI 304 18/10 stainless steel with fully rounded edges
- Cooking chamber lighting via LED Bar fitted into the door
- Door is right hand hinged with adjustable door hinges and handle catch
- The side supports and drip tray can easily be removed for cleaning
- Manual hand spray/wash can be fitted
- 5 Levels of direct steam controlled by a manual control panel situated on the right hand side of the door
- Fitted with a condensate collection bowl, with drain on door
- Timer for cooking from 10 to 120 minutes / infinity
- Supplied without trays and grids
- IPX4 protection rating against water
- Supplied without stand
- Fitted with bidirectional fan motors for even heat distribution

\*\* It is recommend that all combi steamers be installed with water treatment system



**10 TRAY BAKERY**

**SPECIFICATIONS**

MODEL	EKA MKF 1064 S
ELECTRICITY	15.4kW, 380V, 3 Phase + N
DIMENSIONS	850 x 1041 x 1130mm high
WEIGHT	140kg
CAPACITY	(10x) 600 x 400mm trays
RUNNER SPACING	80mm
NUMBER OF FANS	(3x) bidirectional
TEMPERATURE RANGE	30 ~ 270 °C

ORDER CODE

MKF1064S



**6 TRAY BAKERY**

**SPECIFICATIONS**

MODEL	EKA MKF 664 S
ELECTRICITY	10.4kW, 380V, 3 Phase + N
DIMENSIONS	850 x 1041 x 850mm high
WEIGHT	108kg
CAPACITY	(6x) 600 x 400mm trays
RUNNER SPACING	80mm
NUMBER OF FANS	(2x) bidirectional
TEMPERATURE RANGE	30 ~ 270 °C

ORDER CODE

MKF664S



**OPTIONAL EXTRAS (FULL SPECS • PAGE 70 - 71)**

**BAKING TRAYS**

600 x 400 x 30mm

BTA0064

**GRIDS**

600 x 400mm Grid

OGS0064

**STANDS**

Stand for MKF1064S  
Stand for MKF664S

MKF-MKTS1064-L  
MKF-MKTS664-L

**CLEANING**

MANUAL SPRAY KIT

EKF-EKGD





### FEATURES

- Outer casing manufactured from stainless steel
- Cooking chamber is manufactured from 1mm - thick, moulded, AISI 304 18/10 stainless steel with fully rounded edges
- Cooking chamber lighting via LED Bar fitted into the door
- Door is right hand hinged with adjustable door hinges and handle catch
- The side supports and drip tray can easily be removed for cleaning
- Manual hand spray/wash can be fitted
- 5 Levels of direct steam controlled by a manual control panel situated on the right hand side of the door
  - IPX4 protection rating against water
  - Supplied without stand
  - Fitted with bidirectional fan motors for even heat distribution
- Fitted with a condensate collection bowl, with drain on door
- Timer for cooking from 10 to 120 minutes / infinity
- Supplied without trays and grids

\*\* It is recommend that all combi steamers be installed with water treatment system



### 11 PAN GASTRONOMY

#### SPECIFICATIONS

MODEL	EKA MKF 1111 GS
BTU RATING	60 000
ELECTRICITY	0.7kW, 220V, Single Phase
DIMENSIONS	730 x 855 x 1231mm high
WEIGHT	141kg
CAPACITY	(11x) 1/1 GN pans
RUNNER SPACING	68mm
NUMBER OF FANS	(3x) bidirectional
TEMPERATURE RANGE	30 ~ 270 °C

ORDER CODE

MKF1111GS



### 10 TRAY BAKERY

#### SPECIFICATIONS

MODEL	EKA MKF 1064 GS
BTU RATING	61 000
ELECTRICITY	0.7kW, 220V, Single Phase
DIMENSIONS	850 x 1041 x 1231mm high
WEIGHT	158kg
CAPACITY	(10x) 600 x 400mm pans
RUNNER SPACING	80mm
NUMBER OF FANS	(3x) bidirectional
TEMPERATURE RANGE	30 ~ 270 °C

ORDER CODE

MKF1064GS



## OPTIONAL EXTRAS (FULL SPECS • PAGE 70 - 71)

### INSERTS for MKF1111GS

1/1 GN PAN - 55mm	<b>GNF8055</b>
1/1 GN PAN - 55mm (perforated)	<b>GNF8055.P</b>
1/1 GN PAN - 40mm	<b>GNF8040</b>
1/1 GN PAN - 40mm (perforated)	<b>GNF8040.P</b>

### STANDS

Stand for MKF1111GS	<b>MKF-MKTS1111-L</b>
Stand for MKF1064GS	<b>MKF-MKTS1064-L</b>

### BAKING TRAYS for MKF1064GS

600 x 400 x 30mm	<b>BTA0064</b>
------------------	----------------

### GRIDS

1/1 GN GRID (for MKF1111GS)	<b>OGS0011</b>
600 x 400mm Grid (for MKF1064GS)	<b>OGS0064</b>

### CLEANING KIT

MANUAL SPRAY KIT	<b>EKF-EKKD</b>
------------------	-----------------



**FEATURES**

- Outer casing manufactured from stainless steel
- Cooking chamber is manufactured from 1mm - thick, moulded, AISI 304 18/10 stainless steel with fully rounded edges
- Cooking chamber lighting via LED Bar fitted into the door
- Door is right hand hinged with adjustable door hinges and handle catch
- The side supports and drip tray can easily be removed for cleaning
- Manual hand spray/wash can be fitted
- 5 Levels of direct steam controlled by a manual control panel situated on the right hand side of the door
- Fitted with a condensate collection bowl, with drain on door
- Timer for cooking from 10 to 120 minutes / infinity
- Supplied without trays and grids
- IPX3 protection rating against water
- Supplied without stand
- Fitted with bidirectional fan motors for even heat distribution



**6 TRAY**

**SPECIFICATIONS**

MODEL	EKA MKF 664 SP
ELECTRICITY	10.4kW, 380V, 3 Phase + N
DIMENSIONS	850 x 1041 x 850mm high
WEIGHT	108kg
CAPACITY	(6x) 600 x 400mm pans
RUNNER SPACING	80mm
NUMBER OF FANS	(2x) bidirectional
TEMPERATURE RANGE	30 ~ 270 °C

**ORDER CODE**

**MKF664SP**



**OPTIONAL EXTRAS** (FULL SPECS • PAGE 70 - 71)

**BAKING TRAYS**

600 x 400 x 30mm

**BTA0064**

**GRIDS**

600 x 400mm Grid

**OGS0064**

**STAND**

Stand for MKF664SP

**MKF-MKTS664-L**



**FEATURES**

- Outer casing manufactured from stainless steel
- Cooking chamber is manufactured from 1mm thick, moulded, AISI 304 18/10 stainless steel with fully rounded edges
- 2 halogen lights inside the cooking chamber
- The side supports and drip tray can easily be removed for cleaning
- 10 Levels of direct steam controlled by a digital control panel situated below the door
- Fitted with 2 bidirectional fan motors for even heat distribution
- IPX3 protection rating against water
- Bottom hinged door
- Supplied without trays and grids
- *It is recommend that all combi steamers be installed with water treatment system*

- Stackable
- Supplied without stand

**4 PAN DIGITAL CONTROL**

**SPECIFICATIONS**

MODEL	EKA EKF 416 DUD
ELECTRICITY	6.4kW, 380V, 3 Phase + N
DIMENSIONS	790 x 750 x 635mm high
WEIGHT	58kg
CHAMBER DIM	660 x 445 x 380mm high
CAPACITY	(4x) 1/1 GN pans (4x) 600 x 400mm trays

RUNNER SPACING	73mm
TEMPERATURE RANGE	30 ~ 270°C
NUMBER OF PROGRAMS	99
PROG. COOKING STEPS	4
PRE-HEAT TEMPERATURE	180°C

**ORDER CODE**

**EKF416DUD**



**FEATURES**

- Outer casing manufactured from stainless steel
- Cooking chamber is manufactured from 1mm thick, moulded, AISI 304 18/10 stainless steel with fully rounded edges
- Cooking chamber lighting via LED bar fitted into the door
- Available in bottom or right hand hinged door models
- 5 Levels of direct steam controlled by a electromechanical control panel situated on the left hand side of the door
- The side supports and drip tray can easily be removed for cleaning
- Fitted with 2 bidirectional fan motors for even heat distribution
- IPX3 protection rating against water
- Supplied without trays and grids
- *It is recommend that all combi steamers be installed with water treatment system*

- Stackable
- Supplied without stand

**4 PAN MANUAL CONTROL**

**SPECIFICATIONS**

ELECTRICITY	6.4kW, 380V, 3 Phase + N
DIMENSIONS	790 x 785 x 635mm high
WEIGHT	57kg
CHAMBER DIMENSIONS	660 x 430 x 380mm high
CAPACITY	(4x) 1/1 GN pans (4x) 600 x 400mm trays
RUNNER SPACING	73mm
TEMPERATURE RANGE	30 ~ 270°C

**RIGHT HAND HINGED DOOR**

MODEL	EKA EKF 416 ALUD
<b>ORDER CODE</b>	<b>EKF416ALUD</b>

**BOTTOM HINGED DOOR**

MODEL	EKA EKF 416 UD
<b>ORDER CODE</b>	<b>EKF416UD</b>



**OPTIONAL EXTRAS (FULL SPECS • PAGE 70 - 71)**

**INSERTS**

1/1 GN PAN - 65mm	<b>GNF8065</b>
1/1 GN PAN - 65mm (perforated)	<b>GNF8065.P</b>

**BAKING TRAYS**

600 x 400 x 20mm	<b>BTA0013</b>
------------------	----------------

**OVEN STAND**

<b>ORDER CODE</b>	<b>SOE0416</b>
-------------------	----------------

**GRIDS**

1/1 GN GRID	<b>OGS0011</b>
600 x 400mm GRID	<b>OGS0064</b>

**CLEANING**

MANUAL SPRAY KIT	<b>EKF-EKKD</b>
------------------	-----------------



**FEATURES**

- Outer casing manufactured from stainless steel
- Cooking chamber is manufactured from 1mm thick AISI 430 18/10 stainless steel with fully rounded edges
- 1 halogen light fitted into the cooking chamber
- The side supports and drip tray can easily be removed for cleaning
- Electromechanical control panel fitted at the bottom of the door
- Fitted with 2 bidirectional fan motors for even heat distribution
- IPX3 protection rating against water
- Stackable
- Supplied without trays and grids
- Bottom hinged door
- Supplied without stand



**HUMIDIFICATION (PULSE)**

**4 PAN WITH HUMIDIFICATION**

**SPECIFICATIONS**

MODEL	EKA EKF 416
ELECTRICITY	3.4kW, 220V, Single Phase
DIMENSIONS	790 x 750 x 635mm high
WEIGHT	51kg
CHAMBER DIMENSIONS	660 x 445 x 380mm high

CAPACITY	(4x) 1/1 GN pans (4x) 600 x 400mm trays
RUNNER SPACING	73mm
TEMPERATURE RANGE	50 ~ 300°C

**ORDER CODE**

**EKF416**



**FEATURES**

- Outer casing manufactured from stainless steel
- Cooking chamber is manufactured from 1mm thick AISI 304 18/10 stainless steel with fully rounded edges
- 1 halogen light fitted into the cooking chamber
- Available in bottom or right hand hinged door models
- The side supports and drip tray can easily be removed for cleaning
- Electromechanical control panel situated at the bottom of the door
- Fitted with a bidirectional fan motor for even heat distribution
- IPX3 protection rating against water
- Supplied without trays and grids
- Stackable
- Supplied without stand

**4 PAN**

**SPECIFICATIONS**

ELECTRICITY	6.2kW, 380V, 2 Phase + N
DIMENSIONS	790 x 750 x 635mm high
WEIGHT	51kg
CHAMBER DIMENSIONS	660 x 445 x 380mm high
CAPACITY	(4x) 1/1 GN Pans (4x) 600 x 400mm trays
RUNNER SPACE	73mm
TEMP RANGE	50 ~ 300°C

**RIGHT HAND HINGED DOOR**

MODEL	EKA EKF 416 ALP
ORDER CODE	<b>EKF416ALP</b>

**BOTTOM HINGED DOOR**

MODEL	EKA EKF 416 P
ORDER CODE	<b>EKF416P</b>



**OPTIONAL EXTRAS (FULL SPECS • PAGE 70 - 71)**

**BAKING TRAY**

600 x 400 x 20mm

**BTA0013**

**OVEN STAND**

ORDER CODE

**SOE0416**

**OVEN GRIDS**

1/1 GN GRID  
600 x 400mm GRID

**OGS0011**  
**OGS0064**

# CONVECTION OVENS

## EVOLUTION MANUAL CONTROL



### FEATURES

- Outer casing manufactured from stainless steel
- Cooking chamber is manufactured from 1mm thick AISI 304 18/10 stainless steel with fully rounded edges
- 1 halogen light fitted into the cooking chamber
- The side supports and drip tray can easily be removed for cleaning
- Bottom hinged door
- Electromechanical control panel situated at the bottom of the door
- Fitted with 1 unidirectional fan motor for even heat distribution
- (8x) Baking functions - Traditional (static), convection, grilling and combinations of the before mentioned
- IPX3 protection rating against water
- Stackable
- Supplied without stand
- Supplied without grids
- Supplied with (4x) 430 x 345mm baking sheets

### 4 PAN MULTI-FUNCTIONAL

#### SPECIFICATIONS

MODEL	EKA EKF 423 M
ELECTRICITY	2.8kW, 220V, Single Phase
DIMENSIONS	590 x 695 x 590mm high
WEIGHT	35kg
CHAMBER DIMENSIONS	450 x 395 x 330mm high

CAPACITY	(4x) 430 x 345mm trays
RUNNER SPACING	73mm
TEMPERATURE RANGE	50°C ~ 300°C

ORDER CODE

EKF423M



### FEATURES

- Outer casing manufactured from stainless steel
- Cooking chamber is manufactured from 1mm thick AISI 304 18/10 stainless steel with fully rounded edges
- 1 halogen light fitted into the cooking chamber
- The side supports and drip tray can easily be removed for cleaning
- Bottom hinged door
- Electromechanical control panel situated at the top of the door
- Fitted with a unidirectional fan motor for even heat distribution
- IPX3 protection rating against water
- Stackable
- Supplied without stand
- Supplied without grids
- Supplied with (4x) 430 x 345mm baking sheets

### 4 PAN MANUAL CONTROL

#### SPECIFICATIONS

MODEL	EKA EKF 423 P
ELECTRICITY	2.8kW, 220V, Single Phase
DIMENSIONS	590 x 695 x 590mm high
WEIGHT	35kg
CHAMBER DIMENSIONS	450 x 395 x 330mm high

CAPACITY	(4x) 430 x 345mm trays
RUNNER SPACING	73mm
TEMPERATURE RANGE	50°C ~ 300°C

ORDER CODE

EKF423



## OPTIONAL EXTRAS (FULL SPECS • PAGE 70 - 71)

### BAKING TRAY

435 x 315 x 10mm

BTA0043

### OVEN STAND

ORDER CODE

SOE0423

### OVEN GRID

435 x 315mm GRID

COA2003

# OPTIONAL EXTRAS - EKA COMBI STEAMERS & CONVECTION OVENS

## FULL SPECIFICATIONS

### PUSH-IN TROLLEYS



#### FEATURES

- Manufactured from AISI 304 Stainless steel
- Fitted with 4 robust castors, 2 lockable
- Fitted with removable handle



#### 20 PAN PUSH-IN GASTRONOMY TROLLEY

##### SPECIFICATIONS

MODEL	EKA EKCR20TC
DIMENSIONS	740 x 561 x 1750mm high
WEIGHT	34kg
CAPACITY	(20x) 1/1 GN pans
RUNNER SPACING	66mm
ORDER CODE	EKF-EKCR20TC

#### 16 TRAY PUSH-IN BAKING TROLLEY

##### SPECIFICATIONS

MODEL	EKA EKCR16TC
DIMENSIONS	740 x 561 x 1750mm high
WEIGHT	34kg
CAPACITY	(16x) 600 x 400mm baking tray
RUNNER SPACING	80mm
ORDER CODE	EKF-EKCR16TC

#### COMPATIBLE WITH THE FOLLOWING MODELS

- EKA MKF 2011 TS
- EKA MKF 2011 S

### INSERTS

- 1/1GN - 65mm deep
- 1/1GN - 65mm (perforated)
- 1/1GN - 55mm deep
- 1/1GN - 55mm (perforated)
- 1/1GN - 40mm deep
- 1/1GN - 40mm (perforated)

- GNF8065
- GNF8065.P
- GNF8055
- GNF8055.P
- GNF8040
- GNF8040.P

### BAKING TRAYS

- 600 x 400 x 30mm deep
- 600 x 400 x 20mm deep
- 435 x 315 x 10mm deep

- BTA0064
- BTA0013
- BTA0043

### GRIDS

- OVEN GRID - 1/1 GN
- OVEN GRID - 600 x 400mm
- OVEN GRID - 435 x 315mm
- COOLING GRID - 600 x 400mm

- OGS0011
- OGS0064
- COA2003
- CTS0064



### CORE PROBE FOR MILLENNIAL OVENS



CORE PROBE - with support and 1300mm cable  
ORDER CODE EKF-EKSCS

### CLEANING & FLUSHING



MANUAL SPRAY KIT  
ORDER CODE

EKF-EKKD

CLEANING DETERGENT for Millennial Touch Ovens  
ORDER CODE MKF-MKDET

## OVEN STANDS

### FEATURES

- Runners to accommodate GN Pans, 600 x 400mm or 435 x 315mm baking trays
- Manufactured from 1.2mm thick, 430 Stainless steel
- Fitted with 4 height adjustable plastic feet



HEIGHT  
ADJUSTABLE FEET



STURDY STAINLESS STEEL  
CONSTRUCTION

### 11 PAN MILLENNIAL OVENS

#### SPECIFICATIONS

DIMENSIONS	600 x 730 x 750mm high
WEIGHT	23kg
RUNNER SPACING	40mm
COMPATIBLE WITH	EKA MKF 1111 TS EKA MKF 1111 S EKA MKF 1111 GS

ORDER CODE

MKF-MKTS1111-L



### 7 PAN MILLENNIAL OVENS

#### SPECIFICATIONS

DIMENSIONS	600 x 730 x 900mm high
WEIGHT	28kg
RUNNER SPACING	40mm
COMPATIBLE WITH	EKA MKF 711 TS EKA MKF 711 S

ORDER CODE

MKF-MKTS711-L



### 10 PAN MILLENNIAL OVENS

#### SPECIFICATIONS

DIMENSIONS	790 x 850 x 750mm high
WEIGHT	30kg
RUNNER SPACING	40mm
COMPATIBLE WITH	EKA MFK 1064 S EKA MFK 1064 GS

ORDER CODE

MKF-MKTS1064-L



### 6 PAN MILLENNIAL OVENS

#### SPECIFICATIONS

DIMENSIONS	790 x 850 x 900mm high
WEIGHT	35kg
RUNNER SPACING	40mm
COMPATIBLE WITH	EKA MFK 664 S EKA MFK 664 SP

ORDER CODE

MKF-MKTS664-L



### 4 PAN EVOLUTION OVENS

#### SPECIFICATIONS

DIMENSIONS	800 x 750 x 850mm high
WEIGHT	19kg
RUNNER SPACING	70mm
COMPATIBLE WITH	EKA EKF 416 DUD EKA EKF 416 UD EKA EKF 416 ALUD EKA EKF 416 EKA EKF 416 P EKA EKF 416 ALP

ORDER CODE

SOE0416



### 4 PAN CONVECTION OVENS

#### SPECIFICATIONS

DIMENSIONS	600 x 700 x 850mm high
WEIGHT	17kg
RUNNER SPACING	70mm
COMPATIBLE WITH	EKA EKF 423 M EKA EKF 423 P

ORDER CODE

SOE0423





<b>MODEL</b>	EKA MKF 2011 TS ⚡	EKA MKF 2011 S ⚡	EKA MKF 1111 TS ⚡	
<b>CAPACITY</b>	(20x) 1/1 GN Pans or *(16x) 600 x 400mm Baking Trays	(20x) 1/1 GN Pans or *(16x) 600 x 400mm Baking Trays	(11x) 1/1 GN Pans	
<b>RUNNER SPACING</b>	66mm	66mm	68mm	
<b>ELEC / BTU RATING</b>	31kW, 380V, 3 Phase + N	31kW, 380V, 3 Phase + N	15.4kW, 380V, 3 Phase + N	
<b>CONTROL PANEL</b>	Touch Control with Quick Selection knob	Manual Control	Touch Control with Quick Selection knob	
<b>BAKING</b>	✓	✓	✓	
<b>ROASTING</b>	✓	✓	✓	
<b>STEAMING</b>	✓	✓	✓	
<b>STEAM METHOD</b>	Direct Steam - 10 Levels	Direct Steam - 5 Levels	Direct Steam - 10 Levels	

\*16 pan capacity available with optional 16 pan trolley



<b>MODEL</b>	EKA MKF 1064 S ⚡	EKA MKF 1064 GS ⚡	EKA MKF 711 TS ⚡	
<b>CAPACITY</b>	(10x) 600 x 400mm Baking Trays	(10x) 600 x 400mm Baking Trays	(7x) 1/1 GN Pans	
<b>RUNNER SPACING</b>	80mm	80mm	68mm	
<b>ELEC / BTU RATING</b>	15.4kW, 380V, 3 Phase + N	0.7kW, 220V, Single Phase / 61 000	11.4kW, 380V, 3 Phase + N	
<b>CONTROL PANEL</b>	Manual Control	Manual Control	Touch Control with Quick Selection knob	
<b>BAKING</b>	✓	✓	✓	
<b>ROASTING</b>	✓	✓	✓	
<b>STEAMING</b>	✓	✓	✓	
<b>STEAM METHOD</b>	Direct Steam - 5 Levels	Direct Steam - 5 Levels	Direct Steam - 10 Levels	



<b>MODEL</b>	EKA EKF 416 DUD ⚡	EKA EKF 416 UD / ALUD ⚡	EKA EKF 416 P / ALP ⚡	
<b>CAPACITY</b>	(4x) 1/1 GN Pans (4x) 600 x 400mm Baking Trays	(4x) 1/1 GN Pans (4x) 600 x 400mm Baking Trays	(4x) 1/1 GN Pans (4x) 600 x 400mm Baking Trays	
<b>RUNNER SPACING</b>	73mm	73mm	73mm	
<b>ELEC / BTU RATING</b>	6.4kW, 380V, 3 Phase + N	6.4kW, 380V, 3 Phase + N	6.2kW, 380V, 3 Phase + N	
<b>CONTROL PANEL</b>	Digital Control	Manual Control	Manual Control	
<b>BAKING</b>	✓	✓	✓	
<b>ROASTING</b>	✓	✓	✓	
<b>STEAMING</b>	✓	✓	-	
<b>STEAM METHOD</b>	Direct Steam - 10 Levels	Direct Steam - 5 Levels	-	





EKA MKF 1111 S ⚡	EKA MKF 1111 GS ⚡
(11x) 1/1 GN Pans	(11x) 1/1 GN Pans
68mm	68mm
15.4kW, 380V, 3 Phase + N	0.7kW, 220V, Single Phase / 60 000
Manual Control	Manual Control
✓	✓
✓	✓
✓	✓
Direct Steam - 5 Levels	Direct Steam - 5 Levels

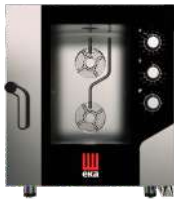

EKA MKF 711 S ⚡	EKA MKF 664 S ⚡	EKA MKF 664 SP ⚡
(7x) 1/1 GN Pans	(6x) 600 x 400mm Baking Trays	(6x) 600 x 400mm Baking Trays
68mm	80mm	80mm
11.4kW, 380V, 3 Phase + N	10.4kW, 380V, 3 Phase + N	10.4kW, 380V, 3 Phase + N
Manual Control	Manual Control	Manual Control
✓	✓	✓
✓	✓	✓
✓	✓	✓
Direct Steam - 5 Levels	Direct Steam - 5 Levels	Direct Steam - 5 Levels



EKA EKF 416 ⚡	EKA EKF 423 M ⚡	EKA EKF 423 ⚡
(4x) 1/1 GN Pans (4x) 600 x 400mm Baking Trays	(4x) 430 x 345mm Baking Trays	(4x) 430 x 345mm Baking Trays
73mm	73mm	73mm
3.4kW, 380V, 3 Phase + N	2.6kW, 240V, Single Phase	2.6kW, 240V, Single Phase
Manual Control	Manual Control	Manual Control
✓	✓	✓
✓	✓	✓
-	-	-
Indirect steam with button	-	-



## FEATURES

- Manufactured from 201 non-magnetic stainless steel
- Doors are fitted with tempered glass
- Internal lighting for improved view of the product
- Fitted with a heavy duty door handle
- Fitted with bi-directional fans
- Adjustable air duct, for more baking varieties
- Timer and Steam function
- RX10D fitted with (4x) adjustable feet. RX6D fitted with (4x) non-slip feet



## 10 TRAY

### SPECIFICATIONS

MODEL	BakeMark RX10D
ELECTRICITY	18kW, 380V, 3 Phase + N
DIMENSIONS	930 x 1320 x 1550mm high
WEIGHT	250kg
CAPACITY	(10x) 600 x 400mm trays
RUNNER SPACING	80mm
TEMPERATURE RANGE	90 ~ 300°C

ORDER CODE                      **COB-RX10D**



### OPTIONAL STAND

DIMENSIONS	920 x 1000 x 480mm high
RUNNER SPACING	40mm

ORDER CODE                      **SOB0010**

## 6 TRAY

### SPECIFICATIONS

MODEL	BakeMark RX6D
ELECTRICITY	9kW, 380V, 3 Phase + N
DIMENSIONS	910 x 1370 x 890mm high
WEIGHT	170kg
CAPACITY	(6x) 600 x 400mm trays
RUNNER SPACING	80mm
TEMPERATURE RANGE	90 ~ 300°C

ORDER CODE                      **COB-RX6D**



### OPTIONAL STAND

DIMENSIONS	910 x 1000 x 770mm high
RUNNER SPACING	40mm

ORDER CODE                      **SOB0006**

## OPTIONAL EXTRAS

### BAKING TRAY

600 x 400 x 30mm

**BTA0064**

### OVEN GRIDS

600 x 400mm

**OGS0064**

### COOLING RACK

600 x 400mm

**CTS0064**



**ADJUSTABLE AIR DUCTS**



**BI-DIRECTIONAL FANS**



**HEAVY DUTY HANDLE**



**FEATURES**

- Manufactured from 201 stainless steel
- Polyurethane foam insulation
- Fitted with a fan circulation system, more uniform proofing effect
- Automatic hydration system - inlet and outlet
- Micro-computer /digital display control panel with timing function
- Big tempered glass windows for improved viewing of the proofing process
- Fitted with (4x) castors

**32 TRAY**

**SPECIFICATIONS**

MODEL	BakeMark XF32B
ELECTRICITY	3.2kW, 230V, Single Phase
DIMENSIONS	1020 x 820 x 1980mm high
WEIGHT	110kg
CAPACITY	(32x) 600 x 400mm trays
TEMPERATURE RANGE	20 ~ 60°C
HUMIDITY	80 ~ 90%



**ORDER CODE**

**PCB-XF32B**

**16 TRAY**

**SPECIFICATIONS**

MODEL	BakeMark XF16B
ELECTRICITY	2.4kW, 230V, Single Phase
DIMENSIONS	500 x 770 x 1980mm high
WEIGHT	55kg
CAPACITY	(16x) 600 x 400mm trays
TEMPERATURE RANGE	20 ~ 60°C
HUMIDITY	80 ~ 90%



**ORDER CODE**

**PCB-XF16B**



**FEATURES**

- Manufactured from 201 stainless steel
- Polyurethane foam insulation
- Fitted with a fan circulation system, more uniform proofing effect
- Automatic hydration system - inlet and outlet
- Manual control panel with timing function
- Tempered glass window for improved viewing of the proofing process
- Fitted with (4x) castors
- Stackable with the BakeMark RX6D convection oven

**10 TRAY**

**SPECIFICATIONS**

MODEL	BakeMark XF10
ELECTRICITY	3kW, 230V, Single Phase
DIMENSIONS	930 x 1200 x 750mm high
WEIGHT	80kg
CAPACITY	(10x) 600 x 400mm trays
RUNNER SPACING	80mm
TEMPERATURE RANGE	20 ~ 60°C
HUMIDITY	80 ~ 90%



**ORDER CODE**

**PCB-XF10**



**STACKABLE**

**OPTIONAL EXTRAS**

**BAKING TRAY**  
600 x 400 x 30mm

**BTA0064**

**OVEN GRIDS**  
600 x 400mm

**OGS0064**

**COOLING RACK**  
600 x 400mm

**CTS0064**



## FEATURES

- Oven body manufactured from stainless steel
- Oven body is insulated
- Oven fitted with hood
- Oven fitted with removable ash drawer for easy cleaning
- Door bottom hinged for easy loading
- Fitted with dial thermometer
- Available in red (on special request)

## 890mm OVEN

### SPECIFICATIONS

MODEL	Empero EMP.PKF-50-S
DIMENSIONS	890 x 825 x 648mm high (Hood + 646mm high)
WEIGHT	190kg
GRILL RACK DIMENSIONS	740 x 650mm
CAPACITY	20kg meat per hour
WORKING TEMPERATURE	250 ~ 500°C

CHARCOAL BLACK  
FIRE RED

**EMP.PKF-50-S**  
**EMP.PKF-50-K**



## COLOUR OPTIONS



CHARCOAL BLACK



FIRE RED

## 710mm OVEN

### SPECIFICATIONS

MODEL	Empero EMP.PKF-40-S
DIMENSIONS	710 x 730 x 666mm high (Hood + 646mm high)
WEIGHT	160kg
GRILL RACK DIMENSIONS	560 x 524mm
CAPACITY	20kg meat per hour
WORKING TEMPERATURE	250 ~ 500°C

CHARCOAL BLACK  
FIRE RED

**EMP.PKF-40-S**  
**EMP.PKF-40-K**



SHOWN WITH OPTIONAL CABINET & TOP GRILL



# PROFESSIONAL CHARCOAL OVENS

## OPTIONAL EXTRAS



**890mm**

### SPECIFICATIONS

DIMENSIONS  
WEIGHT

890 x 825 x 825mm high  
73kg

ORDER CODE

EMP.PKF-50-D



## CABINET

### FEATURES

- Oven cabinet manufactured from stainless steel
- Fitted with robust castors

**710mm**

### SPECIFICATIONS

DIMENSIONS  
WEIGHT

710 x 725 x 825mm high  
63kg

ORDER CODE

EMP.PKF-40-D



**890mm**

### SPECIFICATIONS

DIMENSIONS  
WEIGHT

890 x 825 x 825mm high  
78kg

ORDER CODE

EMP.PKF-50-AS



## STAND

### FEATURES

- Oven Stand manufactured from painted mild steel
- Fitted with 2 shelves
- Fitted with 4 robust castors

**710mm**

### SPECIFICATIONS

DIMENSIONS  
WEIGHT

710 x 725 x 825mm high  
60kg

ORDER CODE

EMP.PKF-40-AS

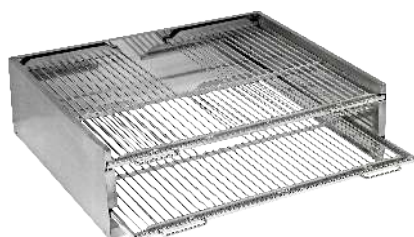

**890mm**

### SPECIFICATIONS

DIMENSIONS  
WEIGHT

890 x 825 x 210mm high  
43kg

ORDER CODE

EMP.PKF-50-US



## TOP GRID

### FEATURES

- Manufactured from high quality stainless steel
- Supplied with 2 grids

**710mm**

### SPECIFICATIONS

DIMENSIONS  
WEIGHT

710 x 725 x 210mm high  
33kg

ORDER CODE

EMP.PKF-40-US



**ONE OVEN FOR PIZZA AND ARTISAN BREADS**

**FEATURES**

- Robust stainless steel construction
- Bottom hinged doors for easy loading
- Steam function available on request
- Additional internal height for baking
- Expanded glass viewing window on oven door
- Top and bottom element controlled individually
- Ceramic base for pizza and artisan breads
- Compatible with 600 x 400mm baking trays



**DOUBLE DECK OVEN - 4 TRAY**

**SPECIFICATIONS**

MODEL	Prismafood Trays 66L
ELECTRICITY	20.4kW, 380V, 3 Phase + N
DIMENSIONS	1500 x 1080 x 745mm high
WEIGHT	225kg
CHAMBER DIMENSIONS	(2x) 1230 x 840 x 175mm high
CHAMBER CAPACITY	(4x) 600 x 400mm trays (6x) 40cm Pizzas
TEMPERATURE RANGE	50 ~ 500°C

ORDER CODE **DOP0066**



**DOUBLE DECK OVEN - 2 TRAY**

**SPECIFICATIONS**

MODEL	Prismafood Trays 44
ELECTRICITY	14kW, 380V, 3 Phase + N
DIMENSIONS	1100 x 1080 x 745mm high
WEIGHT	172kg
CHAMBER DIMENSIONS	(2x) 820 x 840 x 175mm high
CHAMBER CAPACITY	(2x) 600 x 400mm trays (4x) 40cm Pizzas
TEMPERATURE RANGE	50 ~ 500°C

ORDER CODE **DOP0044**



\*WITH OPTIONAL PROVER AND HOOD



**CERAMIC STONE BASE**

## PIZZA / DECK OVENS OPTIONAL EXTRAS



### PROOVER

#### FEATURES

- Stainless steel body with sturdy top to hold the oven weight
- Fitted with double glass doors for easy viewing of product
- Fitted with 4 casters, 2 lockable
- Steam function available on request

#### SPECIFICATIONS

MODEL	Prismafood Cella Inox 6L-66L
ELECTRICITY	2kW, 220V, Single Phase
DIMENSIONS	1500 x 965 x 900mm high
WEIGHT	107kg
CAPACITY	(18x) 600 x 400mm baking trays
RUNNER SPACING	90mm
TEMPERATURE RANGE	10 ~ 60°C
HUMIDIFICATION	Manual fill water container

ORDER CODE **PDP0066**

**COMPATIBLE WITH** Prismafood Trays 66 L



### STANDS

#### SPECIFICATIONS

MODEL	Prismafood ST 66
DIMENSIONS	1520 x 982 x 960mm high
WEIGHT	44kg

ORDER CODE

**SDP0066**



#### SPECIFICATIONS

MODEL	Prismafood ST 44
DIMENSIONS	1117 x 982 x 960mm high
WEIGHT	39kg

ORDER CODE

**SDP0044**



### HOODS

#### SPECIFICATIONS

MODEL	Prismafood KT6L-66L
DIMENSIONS	1500 x 1115 x 120mm high
WEIGHT	18kg

ORDER CODE

**HDP0066**



#### SPECIFICATIONS

MODEL	Prismafood KT4-44
DIMENSIONS	1110 x 1115 x 120mm high
WEIGHT	14kg

ORDER CODE

**HDP0044**



# ELECTRIC PIZZA OVENS TABLE MODEL

**SmartChef**

## FEATURES

- Robust construction
- Internal chamber lighting
- Fitted with a glass viewing windows
- Each deck fitted with a heat gauge
- Top and bottom element is individually controlled
- Fitted with a bottom hinged doors for easy loading
- Supplied with a ceramic pizza stone base
- Fitted with (4x) non-slip rubber feet



## DOUBLE DECK SPECIFICATIONS

MODEL SmartChef HEP-2  
ELECTRICITY 8.4kW, 380V, 3 Phase + N  
DIMENSIONS 890 x 790 x 750mm high  
WEIGHT 90kg  
CHAMBER DIMENSIONS (2x) 610 x 610 x 170mm high  
CHAMBER CAPACITY (4x) 30cm Pizzas per deck  
TEMPERATURE RANGE 50 ~ 400°C

ORDER CODE POS2408



## SINGLE DECK SPECIFICATIONS

MODEL SmartChef HEP-1  
ELECTRICITY 4.2kW, 380V, 3 Phase + N  
DIMENSIONS 890 x 790 x 430mm high  
WEIGHT 52kg  
CHAMBER DIMENSIONS (1x) 610 x 610 x 170mm high  
CHAMBER CAPACITY (4x) 30cm Pizzas per deck  
TEMPERATURE RANGE 50 ~ 400°C

ORDER CODE POS1404

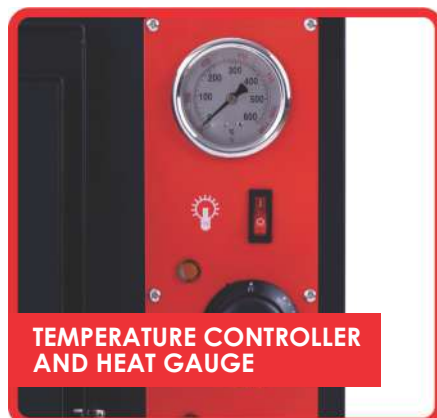

TEMPERATURE CONTROLLER AND HEAT GAUGE



EACH DECK FITTED WITH A CERAMIC PIZZA STONE BASE



INDIVIDUALLY CONTROLLED TOP AND BOTTOM ELEMENTS



# ELECTRIC PIZZA OVENS TABLE MODEL

**SmartChef**

## FEATURES

- Body manufactured from stainless steel
- Internal chamber lighting
- Fitted with a glass viewing window
- Fitted with (4x) non-slip rubber feet
- Top and bottom element is individually controlled
- Fitted with a bottom hinged door for easy loading
- Supplied with a pizza stone base



## DOUBLE DECK SPECIFICATIONS

MODEL SmartChef HEP-2ST  
ELECTRICITY 3kW, 240V, Single Phase  
DIMENSIONS 560 x 570 x 440mm high  
WEIGHT 27kg  
CHAMBER DIMENSIONS (2x) 400 x 400 x 155mm high  
CHAMBER CAPACITY (1x) 30cm Pizza  
TEMPERATURE RANGE 50 ~ 350°C

ORDER CODE

POS2102



## SINGLE DECK SPECIFICATIONS

MODEL SmartChef HEP-1ST  
ELECTRICITY 2kW, 240V, Single Phase  
DIMENSIONS 560 x 570 x 280mm high  
WEIGHT 18kg  
CHAMBER DIMENSIONS (1x) 400 x 400 x 155mm high  
CHAMBER CAPACITY (1x) 30cm Pizza  
TEMPERATURE RANGE 50 ~ 350°C

ORDER CODE

POS1101



MANUAL TEMPERATURE  
AND TIMER CONTROLS



FITTED WITH  
NON-SLIP FEET



INDIVIDUALLY CONTROLLED  
TOP AND BOTTOM ELEMENTS

# ELECTRIC PIZZA OVENS TABLE MODEL



## FEATURES

- Body manufactured from stainless steel
- Refractory stone cooking surface
- Rockwool insulation
- Sheathed heating elements
- The internal lighting
- Fitted with (4x) non-slip rubber feet

## DOUBLE DECK

### SPECIFICATIONS

MODEL	Prismafood Basic 2/40 VERTO 4T
ELECTRICITY	2.4kW, 230V, Single Phase
DIMENSIONS	568 x 500 x 430mm
WEIGHT	32kg
CHAMBER DIMENSIONS	(2x) 410 x 360 x 90mm
CHAMBER CAPACITY	(1x) 30cm Pizza
TEMPERATURE RANGE	40 ~ 320°C

ORDER CODE:

POP0240



## SINGLE DECK

### SPECIFICATIONS

MODEL	Prismafood Basic 1/40 VERTO 2T
ELECTRICITY	1.6kW, 230V, Single Phase
DIMENSIONS	568 x 500 x 280mm
WEIGHT	21kg
CHAMBER DIMENSIONS	(1x) 410 x 360 x 90mm
CHAMBER CAPACITY	(1x) 30cm Pizza
TEMPERATURE RANGE	40 ~ 320°C

ORDER CODE:

POP0140

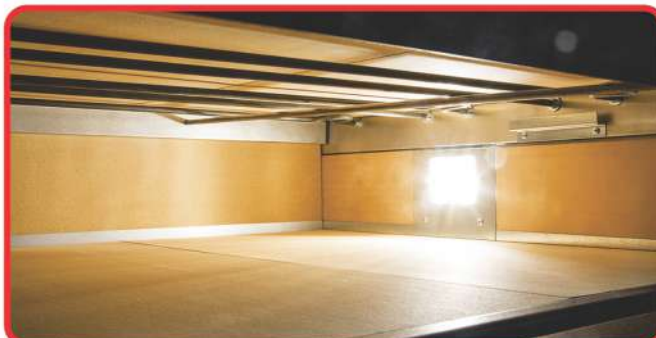

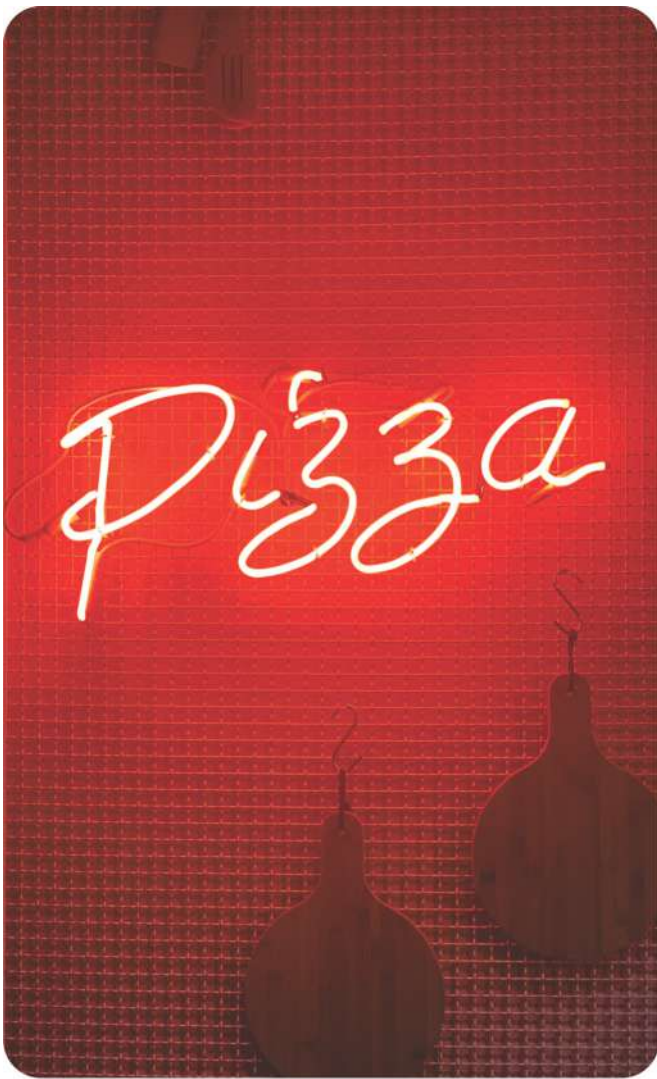

# ELECTRIC DECK OVENS WITH HUMIDIFICATION



**INTRODUCING**  
**BakeMark**  
Smartstone 33

- Electronic control
- Humidification
- Stone base

### FEATURES

- Robust body manufactured from stainless steel
- 16 program settings
- Top hinged door with front glass for easy loading and viewing
- Bottom stone on each deck
- Steam function
- Each deck fitted with adjustable vent
- Fitted with (4x) robust casters

### TRIPLE DECK

#### SPECIFICATIONS

MODEL	BakeMark SmartStone XYF-39H-N
ELECTRICITY	25kW, 380V, 3 Phase + N
DIMENSIONS	1750 x 1080 x 1750mm high
WEIGHT	750kg
CHAMBER DIMENSIONS	(3x) 1300 x 750 x 170mm high
CHAMBER CAPACITY	(3x) 600 x 400mm trays
TEMPERATURE RANGE	20 ~ 300°C

ORDER CODE

DOB/S3309



## OPTIONAL EXTRAS

### BAKING TRAY

600 x 400 x 30mm

BTA0064





- FEATURES**
- Robust construction
  - Bottom hinged doors for easy loading
  - Top and bottom elements individually controlled for each deck
  - Individually controlled internal lighting per deck
  - Fitted with glass viewing windows
  - Timer with buzzer individually controlled per deck
  - Fitted with (4x) castors

**TRIPLE DECK 1600mm**

**SPECIFICATIONS**

MODEL BakeMark HEO-39  
 ELECTRICITY 25kW, 380V, 3 Phase + N  
 DIMENSIONS 1650 x 815 x 1530mm high  
 WEIGHT 230kg  
 CHAMBER DIMENSIONS (3x) 1300 x 620 x 220mm  
 CHAMBER CAPACITY (3x) 600 x 400mm trays  
 TEMPERATURE RANGE 50 ~ 400°C

ORDER CODE **DOB3309**



**TRIPLE DECK 1200mm**

**SPECIFICATIONS**

MODEL BakeMark HEO-36  
 ELECTRICITY 19.5kW, 380V, 3 Phase + N  
 DIMENSIONS 1220 x 815 x 1530mm high  
 WEIGHT 165kg  
 CHAMBER DIMENSIONS (3x) 860 x 620 x 220mm  
 CHAMBER CAPACITY (2x) 600 x 400mm trays  
 TEMPERATURE RANGE 50 ~ 400°C

ORDER CODE **DOB3206**



**OPTIONAL EXTRAS**

**BAKING TRAY**  
 600 x 400 x 30mm

**BTA0064**



## FEATURES

- Robust construction
- Top and bottom elements individually controlled for each deck
- Fitted with the glass viewing window
- HEO-24 & HEO-22 - Fitted with (4x) castors
- Bottom hinged doors for easy loading
- Individually controlled internal lighting per deck
- Timer with buzzer individually controlled per deck
- HEO-11 - Fitted with (4x) non-slip rubber feet



## DOUBLE DECK 1200mm

### SPECIFICATIONS

MODEL	BakeMark HEO-24
ELECTRICITY	13.2kW, 380V, 3 Phase + N
DIMENSIONS	1220 x 815 x 1260mm high
WEIGHT	125kg
CHAMBER DIMENSIONS	(2x) 860 x 620 x 220mm
CHAMBER CAPACITY	(2x) 600 x 400mm tray
TEMPERATURE RANGE	50 ~ 400°C

### ORDER CODE

DOB2204



## DOUBLE DECK 900mm

### SPECIFICATIONS

MODEL	BakeMark HEO-22
ELECTRICITY	6.4kW, 230V, Single Phase
DIMENSIONS	880 x 580 x 770mm high
WEIGHT	50kg
CHAMBER DIMENSIONS	(2x) 620 x 420 x 160mm
CHAMBER CAPACITY	(1x) 600 x 400mm tray
TEMPERATURE RANGE	50 ~ 300°C

### ORDER CODE

DOB2102



## SINGLE DECK 900mm

### SPECIFICATIONS

MODEL	BakeMark HEO-11
ELECTRICITY	3.2kW, 230V, Single Phase
DIMENSIONS	880 x 580 x 350mm high
WEIGHT	35kg
CHAMBER DIMENSIONS	(1x) 620 x 420 x 160mm
CHAMBER CAPACITY	(1x) 600 x 400mm tray
TEMPERATURE RANGE	50 ~ 300°C

### ORDER CODE

DOB1101



## OPTIONAL EXTRAS

### BAKING TRAY

600 x 400 x 30mm

BTA0064

## FEATURES

- Body manufactured from 0.8mm, 430 grade stainless steel
- Flame-out protection function
- Gas burner manufactured from SS304 stainless steel
- Fitted with timer to control
- Top hinged door with front glass for easy loading and viewing
- Fitted with heat resisting light
- Aluminum plated chambers for increased thermal radiation
- Ceramic stone bases on each deck
- Double electromagnetic valve control
- Fitted with high quality digital display panels
- Each deck is fitted with a pizza stone base



### 3 DECK, 9 TRAY WITH HUMIDIFICATION

#### SPECIFICATIONS

MODEL	BakeMark Smartstone HLY-309E-NM
BTU RATING	70 000
DIMENSIONS	1815 x 925 x 1720mm high
WEIGHT	450kg
CHAMBER DIMENSIONS	(3x) 1320 x 700 x 185mm high
CHAMBER CAPACITY	(3x) 600 x 400mm trays
TEMPERATURE RANGE	20 ~ 400°C

ORDER CODE **DOB/S3309G**



### 2 DECK, 4 TRAY NO HUMIDIFICATION

#### SPECIFICATIONS

MODEL	BakeMark Smartstone HLY-204E-NM
BTU RATING	35 000
DIMENSIONS	1330 x 850 x 1400mm high
WEIGHT	250kg
CHAMBER DIMENSIONS	(2x) 870 x 670 x 185mm high
CHAMBER CAPACITY	(2x) 600 x 400mm trays
TEMPERATURE RANGE	20 ~ 400°C

ORDER CODE **DOB/S2204G**



## OPTIONAL EXTRAS

**BAKING TRAY**  
600 x 400 x 30mm

**BTA0064**

## ALUMINUM BAKING TRAYS

**SmartChef**



### 600 x 400 x 30mm

MODEL  
DIMENSIONS

SmartChef BTA0064  
600 x 400 x 30mm deep

ORDER CODE

BTA0064

### 435 x 315 x 10mm

MODEL  
DIMENSIONS

SmartChef BTA0043  
435 x 315 x 10mm deep

ORDER CODE

BTA0043

## STAINLESS STEEL OVEN GRIDS



### 600 x 400mm

MODEL  
DIMENSIONS

SmartChef OGS0064  
600 x 400mm

ORDER CODE

OGS0064

### GN 1/1

MODEL  
DIMENSIONS

SmartChef OGS0011  
530 x 325mm

ORDER CODE

OGS0011

## STAINLESS STEEL COOLING RACKS



### 600 x 400mm

MODEL  
DIMENSIONS

SmartChef CTS0064  
600 x 400mm

ORDER CODE

CTS0064





**prismafood**

▶▶ **solutions**

*Because Italians know pizza!*





COMPACT  
DESIGN



210mm

210mm

Same size as an  
A4 page

AVAILABLE IN 3 COLOURS



Goshen<sup>®</sup>  
Cool & Compact

## SECTION INDEX

Back bar coolers .....	102
Coffee brewers .....	92
Coffee urns .....	93
Frappe makers .....	95
Gelato machines .....	98
Hot water urns .....	93
Ice cream machines .....	98-101
Ice crushers .....	95
Juice dispensers .....	96
Milkshake machines .....	95
Slush machines .....	97
Soft serve machines .....	99-101
Urns .....	93

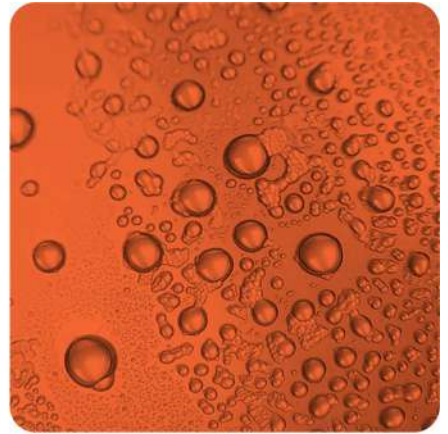

## FEATURES

- Manufactured from Stainless Steel 304
- Built-in, concealed heating element with "dry-boil" protection
- Fitted with cool-touch handles
- Fitted with a non-drip tap and clear water gauge
- Supplied with a removable drip tray
- Double walled body for improved insulation
- Waterproof on/off switch for improved safety
- Equipped with a "twist-lock" lid to avoid spilling
- Supplied with an internal, stainless steel coffee strainer
- Available in black(matt) and stainless steel



### 14 LITRE

#### SPECIFICATIONS

MODEL Caterlot 0014  
 ELECTRICITY 1.5kW, 220V, Single Phase  
 DIMENSIONS Ø310 x 517mm high  
 WEIGHT 4kg  
 CAPACITY 14Lt

Stainless Steel  
 Matt Black

**CBC0014**  
**CBC0014-B**



### 8 LITRE

#### SPECIFICATIONS

MODEL Caterlot 0008  
 ELECTRICITY 0.95kW, 220V, Single Phase  
 DIMENSIONS Ø230 x 504mm high  
 WEIGHT 3kg  
 CAPACITY 8Lt

Stainless Steel  
 Matt Black

**CBC0008**  
**CBC0008-B**



**TWIST-LOCK LID**



**COOL-TOUCH HANDLES**



**REMOVABLE DRIP TRAY**





## FEATURES

- Manufactured from Stainless Steel 304
- Double walled body for improved insulation
- Built-in, concealed heating element with "dry-boil" protection
- Fitted with an adjustable thermostat (30 ~ 110°C), with "keep warm" function
- Waterproof on/off switch for improved safety
- Fitted with cool-touch handles
- Equipped with a "twist-lock" lid to avoid spilling
- Fitted with a non-drip tap and clear water gauge
- Supplied with a removable drip tray
- Available in matt black, matt red, yellow, copper colour and stainless steel



## 24 LITRE SPECIFICATIONS

MODEL Caterlot 0024  
 ELECTRICITY 2.5kW, 220V, Single Phase  
 DIMENSIONS Ø310 x 640mm high  
 WEIGHT 5kg  
 CAPACITY 24Lt

Stainless Steel  
 Copper Colour  
 Yellow  
 Matt Black  
 Matt Red

URN0024  
 URN0024-O  
 URN0024-MY  
 URN0024-B  
 URN0024-MR



## 16 LITRE SPECIFICATIONS

MODEL Caterlot 0016  
 ELECTRICITY 2.5kW, 220V, Single Phase  
 DIMENSIONS Ø310 x 517mm high  
 WEIGHT 4kg  
 CAPACITY 16Lt

Stainless Steel  
 Copper Colour  
 Yellow  
 Matt Black  
 Matt Red

URN0016  
 URN0016-O  
 URN0016-MY  
 URN0016-B  
 URN0016-MR



## 9 LITRE SPECIFICATIONS

MODEL Caterlot 0009  
 ELECTRICITY 1.5kW, 220V, Single Phase  
 DIMENSIONS Ø230 x 504mm high  
 WEIGHT 3kg  
 CAPACITY 9Lt

Stainless Steel  
 Copper Colour  
 Yellow  
 Matt Black  
 Matt Red

URN0009  
 URN0009-O  
 URN0009-MY  
 URN0009-B  
 URN0009-MR



NON-DRIP TAP



WATERPROOF SWITCH



MANUAL THERMOSTAT



**FEATURES**

- Modern design ABS housing with an unbreakable food grade Polycarbonate jar
- Easy to use digital touch control panel with various speed, time and pulse action
- Polycarbonate soundproof cover to reduce noise
- Fitted with a stainless steel blade assembly
- Removable dosing cup and stir bar included
- Fitted with an over-heat, auto shut-off safety function
- Industrial grade, heavy duty motor with pure copper coil
- Housing fitted with non-slip base

**WITH SOUND COVER**

**SPECIFICATIONS**

MODEL	SmartBlend VORTEX SC 1680C
ELECTRICITY	1.68kW, 220V, Single Phase
DIMENSIONS	230 x 250 x 540mm high (closed) 230 x 250 x 790mm high (open)
WEIGHT	9kg
SPEED	32 000rpm - Touch control
JAR CAPACITY	2Lt

**ORDER CODE**

**BSB1680C/C**



**FEATURES**

- ABS housing with unbreakable food grade Polycarbonate jar
- Precision blending with pulse action
- Removable dosing cup and stir bar included
- Industrial grade, heavy duty motor with pure copper coil
- Variable speed control
- Fitted with a stainless steel blade assembly
- Fitted with an over-heat, auto shut-off safety function
- Housing fitted with non-slip base



**SPECIFICATIONS**

MODEL	SmartBlend VORTEX 1680
ELECTRICITY	1.68kW, 220V, Single Phase
DIMENSIONS	230 x 250 x 520mm high
WEIGHT	6kg
SPEED	32 000rpm - Analog control
JAR CAPACITY	2Lt

**ORDER CODE**

**BSB1680**



**SPECIFICATIONS**

MODEL	SmartBlend STORM 112
ELECTRICITY	1.1kW, 220V, Single Phase
DIMENSIONS	225 x 210 x 490mm high
WEIGHT	4kg
SPEED	26 000rpm - Analog control
JAR CAPACITY	2Lt

**ORDER CODE**

**BSB0112**

**AVAILABLE EXTRAS**

2Lt Jar & Tamper  
Compatible with - VORTEX SC 1680C & VORTEX 1680  
**ORDER CODE**      **BSB1680-JAR2L**

2Lt Jar & Tamper  
Compatible with - STORM 112  
**ORDER CODE**      **BSB0112-JAR2L**

# MILKSHAKE MACHINE / FRAPPE MAKER



- FEATURES**
- Manufactured from durable, food-grade ABS material
  - Fitted with a two speed on/off switch
  - Motor ventilation grooves prevents over heating
  - Fitted with a powerful 400W motor with re-activated thermal cut-off for the safety of the appliance and the protection of the motor
  - Fitted with non-slip feet
  - Supplied with a stainless steel mixer cup. Optional ABS cup available
  - Available in 5 colours to compliment any bar or kitchen theme

**SPECIFICATIONS**

MODEL	Johny AK/2-2T
ELECTRICITY	0.4kW, 220V, Single Phase
DIMENSIONS	170 x 175 x 465mm high
WEIGHT	4.5kg
SPEED	14 000 / 20 000rpm
CONTAINER CAPACITY	1 000ml

<b>GREY</b>	<b>MMJ0001</b>
<b>RED</b>	<b>MMJ0002</b>
<b>GREEN</b>	<b>MMJ0003</b>
<b>BLUE</b>	<b>MMJ0004</b>
<b>SILVER</b>	<b>MMJ0005</b>



**AVAILABLE COLOURS**   ● Dark Red   ● Dark Blue   ● Dark Green   ● Dark Grey   ● Silver



**1L STAINLESS STEEL CUP**  
ORDER CODE      **MMJ1000**



**1L POLYCARBONATE CUP**  
ORDER CODE      **MMJ2000**

# ICE CRUSHER



- FEATURES**
- Stainless steel body cover
  - Front face cover manufactured from ABS
  - Transparent feed cover. Manufactured from polycarbonate
  - 2Lt transparent ice bucket with water draining grate. Manufactured from polycarbonate
  - Isolating double-wall housing prevents immediate melting of ice
  - Fitted with a 120W motor with thermal protection
  - Fitted with Auto-stop safety micro switches on feed cover and ice bucket
  - Fitted with non-slip feet

**SPECIFICATIONS**

MODEL	Johny AK/14 ECO
ELECTRICITY	0.12kW, 220V, Single Phase
DIMENSIONS	300 x 190 x 400mm high
WEIGHT	7kg
SPEED	40 rpm
CRUSH CAPACITY	40 kg/h
BUCKET CAPACITY	2Lt

<b>ORDER CODE</b>	<b>ICJ0001</b>
-------------------	----------------



## FEATURES

- Body manufactured from high quality stainless steel
- Electromagnetic drive shaft
- Supplied with drip trays
- High resistance, non-toxic Polycarbonate tank
- Air cooling
- Fitted with (4x) non-slip feet



### 3 x 12L Juice Dispenser

#### SPECIFICATIONS

**MODEL** PolarCab LSJ12X3  
**ELECTRICITY** 0.38kW, 220V, Single Phase  
**DIMENSIONS** 610 x 410 x 660mm high  
**WEIGHT** 36kg  
**CAPACITY** (3x) 12L  
**TEMPERATURE RANGE** 7 ~ 12 °C  
**REFRIGERANT GAS** R134a

**ORDER CODE**

**JDP0312**



### 2 x 12L Juice Dispenser

#### SPECIFICATIONS

**MODEL** PolarCab LSJ12X2  
**ELECTRICITY** 0.28kW, 220V, Single Phase  
**DIMENSIONS** 410 x 410 x 660mm high  
**WEIGHT** 27kg  
**CAPACITY** (2x) 12L  
**TEMPERATURE RANGE** 7 ~ 12 °C  
**REFRIGERANT GAS** R134a

**ORDER CODE**

**JDP0212**





## FEATURES

- R304, Stainless steel Body panel, louver panel for ventilation
- Durable, high density PC tanks with brandable lids
- Imported European brand compressor, durable, energy saving, low noise
- Dual beater mixing system (inner and outer cooling cylinder) to avoid "ice jam"
- Electromagnetic drive shaft
  - Fitted with an all red copper condenser
  - Fitted with (4x) non-slip feet
- Includes drip trays



### 3 x 10L SLUSH MACHINE

#### SPECIFICATIONS

MODEL	PolarCab XRJ10LX3
ELECTRICITY	0.8kW, 220V, Single Phase
DIMENSIONS	610 x 510 x 770mm high
WEIGHT	63kg
VOLUME	(3x) 10L
TEMPERATURE RANGE	-2 ~ -3°C
REFRIGERANT GAS	R134a

ORDER CODE **SMP0310**



### 2 x 10L SLUSH MACHINE

#### SPECIFICATIONS

MODEL	PolarCab XRJ10LX2
ELECTRICITY	0.6kW, 220V, Single Phase
DIMENSIONS	430 x 510 x 770mm high
WEIGHT	41kg
VOLUME	(2x) 10L
TEMPERATURE RANGE	-2 ~ -3°C
REFRIGERANT GAS	R134a

ORDER CODE

**SMP0210**



### 1 x 10L SLUSH MACHINE

#### SPECIFICATIONS

MODEL	PolarCab XRJ10LX1
ELECTRICITY	0.6kW, 220V, Single Phase
DIMENSIONS	220 x 510 x 770mm high
WEIGHT	28kg
VOLUME	10L
TEMPERATURE RANGE	-2 ~ -3°C
REFRIGERANT GAS	R134a

ORDER CODE

**SMP0110**



# GELATO MACHINES COUNTER TOP



## FEATURES

- Body manufactured from stainless steel
- Compact design uses less workspace
- Transparent polycarbonate feeder hopper located in the front of the machine for easy and accurate operation
- Large stainless steel freezing cylinder increases output and "fluffiness" of the ice cream
- Retractable, rotating mixer blade inside the cylinder further improves the smoothness of the ice cream
- Fitted with a powerful, energy saving compressor
- Fitted with a digital, waterproof control panel
- Fitted with (4x) non-slip feet

## SPECIFICATIONS

MODEL	Goshen BQ12T
ELECTRICITY	1kW, 220V, Single Phase
DIMENSIONS	500 x 705 x 800mm high
WEIGHT	110kg
HOPPER VOLUME	5.1Lt
REFRIGERANT GAS	R404a
HOURLY OUTPUT	10 ~ 14Lt/hour

## ORDER CODE

ICM/BQ12T



## OPTIONAL EXTRAS

ICE CREAM INSERT - 360 x 165 x 120mm deep  
ORDER CODE **GNI8120**

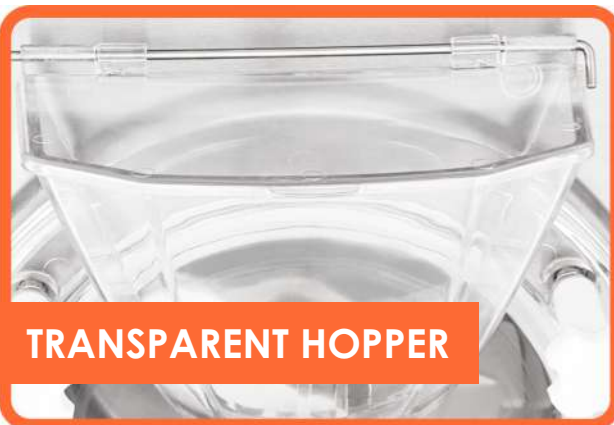

**TRANSPARENT HOPPER**

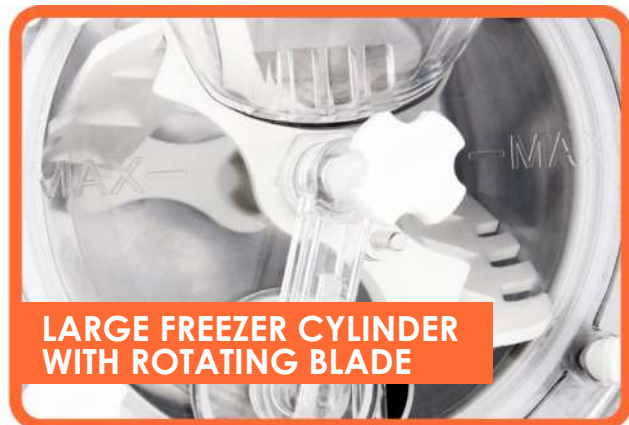

**LARGE FREEZER CYLINDER WITH ROTATING BLADE**



**WATERPROOF DIGITAL CONTROL PANEL**



# SOFT SERVE MACHINES COUNTER TOP



## FEATURES

- Exquisite modern design. Small and portable
- Silent operation
- Fitted with a stainless steel refrigerated hopper
- Mixer installed inside hopper makes for smoother ice cream
- Fitted with a stainless steel beater
- Built-in air pump
- Fitted with a 7inch, touch screen control panel
- One-touch thaw function
- Fitted with (4x) non-slip feet



## FEATURES

- Exquisite modern design. Small and portable
- Silent operation
- Fitted with a stainless steel hopper
- Fitted with a food grade plastic beater
- Built-in air pump
- Fitted with a 5inch, waterproof, touch control panel
- Built-in thaw function
- Fitted with (4x) non-slip feet
- Available in 3 exciting candy colours



## COOL & COMPACT

### SPECIFICATIONS

MODEL	Goshen ST16RELW
ELECTRICITY	1.25kW, 220V, Single Phase
DIMENSIONS	210 x 554 x 740mm high
WEIGHT	45kg
HOPPER VOLUME	6Lt
REFRIGERANT GAS	R290
HOURLY OUTPUT	16 ~ 18Lt/hour
REALISTIC OUTPUT	12Lt (100 x 120g servings)

ORDER CODE **SSM/ST16RELW-W**

## COMPACT

### SPECIFICATIONS

MODEL	Goshen ST16E
ELECTRICITY	1.15kW, 220V, Single Phase
DIMENSIONS	210 x 554 x 740mm high
WEIGHT	43kg
HOPPER VOLUME	6Lt
REFRIGERANT GAS	R290
HOURLY OUTPUT	16 ~ 18Lt/hour
REALISTIC OUTPUT	12Lt (100 x 120g servings)

ORDER CODE **SSM/ST16E-W**  WHITE  
**SSM/ST16E-P**  PINK  
**SSM/ST16E-Y**  YELLOW



# SOFT SERVE MACHINES WITH REFRIGERATED HOPPER



## FEATURES

- Compact design - can be installed in small areas
- Unique mixing shaft manufactured with stainless steel axes with non-toxic corkscrew plastic scrapers
- Fitted with 2 stainless steel refrigerated hoppers with clear plastic lids for easy viewing
- Quick recovery time
- Low noise and vibrations
- Gravity feed machine
- Easy to disassemble and clean
- Fitted with removable plastic drip tray
- IT Push panel (one touch switch) controller with indicator light for easy operation



## FLOOR STANDING

### SPECIFICATIONS

MODEL	PolarCab SQL-922
ELECTRICITY	2kW, 230V, Single Phase
DIMENSIONS	550 x 700 x 1330mm high
WEIGHT	140kg
REFRIGERANT GAS	R22
HOPPER CAPACITY	(2x) 5.8Lt
OUTPUT PER HOUR	180 cones

ORDER CODE

SSM1002



## TABLE MODEL

### SPECIFICATIONS

MODEL	PolarCab SQL-922C
ELECTRICITY	2kW, 230V, Single Phase
DIMENSIONS	550 x 700 x 1080mm high
WEIGHT	115kg
REFRIGERANT GAS	R22
HOPPER CAPACITY	(2x) 5.8Lt
OUTPUT PER HOUR	180 cones

ORDER CODE

SSM1001



## SOFT SERVE MACHINES WITH DOUBLE BARREL

**SmartChef**



### FEATURES

- Easy to operate touch control panel
- Fitted with (2x) stainless steel hoppers
- Quick recovery time
- Low noise and vibration
- Gravity feed machine
- Easy to disassemble and clean
- Fitted with removable plastic drip tray for easy cleaning
- Fitted with (4x) castors

### FLOOR STANDING

#### SPECIFICATIONS

MODEL	SmartChef HIM-02
ELECTRICITY	1.7kW, 230V, Single Phase
DIMENSIONS	700 x 900 x 1435mm high
WEIGHT	135kg
REFRIGERANT GAS	R22/R404A
HOPPER CAPACITY	(2x) 6.5L
OUTPUT PER HOUR	90 cones

ORDER CODE

SSM-HIM-02



## FEATURES

- Black units - Outer cabinet manufactured from coated mild steel
- Stainless steel units - Outer cabinet manufactured stainless steel
- High pressure injected 40mm cyclopentane insulation
- Cabinet interior manufactured from compressed aluminium
- 14W square fan assisted condenser
- Automatic defrost function
- Doors are fitted with tempered glass
- Fitted with adjustable feet for easy leveling
- Fitted with a digital temperature control and display
- Smooth action sliding doors / hinged doors
- Standard with internal LED lights and locks



## 3 DOOR

### SPECIFICATIONS

**MODEL** PolarCab LG320  
**ELECTRICITY** 0.67kW, 220V, Single Phase  
**EXTERNAL DIMENSIONS** 1350 x 520 x 850mm high  
**WEIGHT** 80kg  
**INTERNAL DIMENSIONS** 1260 x 385 x 700mm high  
**VOLUME** 320Lt  
**TEMPERATURE RANGE** 2 ~ 10°C  
**REFRIGERANT GAS** R600a  
**SHELVES SUPPLIED** (6x) 400 x 345mm

**SLIDING DOORS - BLACK** BBP0003  
**HINGED DOORS - BLACK** BBP1003  
**HINGED DOORS - S/STEEL** BBP3003



## 2 DOOR

### SPECIFICATIONS

**MODEL** PolarCab LG198  
**ELECTRICITY** 0.23kW, 220V, Single Phase  
**EXTERNAL DIMENSIONS** 900 x 520 x 850mm high  
**WEIGHT** 62kg  
**INTERNAL DIMENSIONS** 820 x 385 x 700mm high  
**VOLUME** 198Lt  
**TEMPERATURE RANGE** 2 ~ 10°C  
**REFRIGERANT GAS** R600a  
**SHELVES SUPPLIED** (4x) 400 x 345mm

**SLIDING DOORS - BLACK** BBP0002  
**HINGED DOORS - BLACK** BBP1002  
**HINGED DOORS - S/STEEL** BBP3002



## SINGLE DOOR

### SPECIFICATIONS

**MODEL** PolarCab LG128  
**ELECTRICITY** 0.18kW, 220V, Single Phase  
**EXTERNAL DIMENSIONS** 600 x 520 x 850mm high  
**WEIGHT** 46kg  
**INTERNAL DIMENSIONS** 520 x 385 x 700mm high  
**VOLUME** 128Lt  
**TEMPERATURE RANGE** 2 ~ 10°C  
**REFRIGERANT GAS** R600a  
**SHELVES SUPPLIED** (2x) 500 x 345mm

**HINGED DOOR - BLACK** BBP1001  
**HINGED DOOR - S/STEEL** BBP3001



**DIGITAL TEMPERATURE CONTROL AND DISPLAY**



# DRINK MIXER



# ICE CRUSHER



# PRE-RINSE UNITS

RELIABILITY BUILT IN

# CONSERVE UP TO

# 60%

# WATER



# WASHING & HARDWARE

## SECTION INDEX

<i>Dishwashers</i>	
• Conveyor .....	112
• Front loading .....	107, 109
• Hoodtype .....	108, 110-111
Faucets .....	113
Glass washers .....	106
Hand wash basins .....	114
Hose reels .....	114
Janitor trolleys .....	115
Knee operated hand wash basins .....	114
Laundry trolleys .....	115
Overhead sprays .....	113
Pre-rinse sprays .....	113



## FEATURES

- The machine body is manufactured from AISI 304 18/10 stainless steel
- The powerful 1HP wash pump, designed and manufactured by Omniwash, ensures maximum performance wash after wash
- The rinse boiler is fitted with internal baffles to provide consistent clean rinse water and prevents the rinse temperature from dropping off too quickly
- High performance wash arms and jets are designed to work together with the Omniwash wash pump to deliver maximum washing action
- The powerful jets can cut through baked-on food soils
- Fitted with easy-to-use illustrated push buttons
- The wash and rinse arms are easy to remove and clean
- Wash tank filters keeps the machine free of excess food soils resulting in cleaner water for longer



## SINGLE PHASE GRAVITY DRAIN

### SPECIFICATIONS

MODEL	Omniwash Jolly 40
ELECTRICITY	3.15kW, 220V, Single Phase
DIMENSIONS	475 x 505 x 720mm high
WEIGHT	40kg
PC BOARDS	No - Electro Mechanical
MAX GLASS HEIGHT	290mm high
CYCLE TIME	120 seconds
CYCLES PER HOUR	30
HOURLY OUTPUT	Up to 1200 glasses
DRAIN PUMP	No - Gravity Drain
BASKET DIMENSIONS	400 x 400 x 100mm high
BASKETS SUPPLIED	1 x Open Bowl Dish Rack 1 x Cutlery Holder
BOILER CAPACITY	5.5Lt
WASH TANK CAPACITY	14Lt
WASH TANK TEMP	55°C
RINSE TEMP	80 ~ 85°C

### ORDER CODE

**GWO0040**



**\* WASTE POINT, NOT HIGHER THAN 100mm ABOVE FLOOR LEVEL IS REQUIRED FOR ALL GRAVITY DRAIN MODELS**

## OPTIONAL STAND

STAINLESS STEEL WITH BASKET RUNNERS - 600mm high

**SDO0040**



## FEATURES

- The machine body is manufactured from AISI 304 18/10 stainless steel
- The powerful 1HP wash pump, designed and manufactured by Omniwash, ensures maximum performance wash after wash
- The rinse boiler is fitted with internal baffles to provide consistent clean rinse water and prevents the rinse temperature from dropping off too quickly
- High performance wash arms and jets are designed to work together with the Omniwash wash pump to deliver maximum washing action
- The powerful jets can cut through baked-on food soils
- Fitted with easy-to-use illustrated push buttons
- The wash and rinse arms are easy to remove and clean
- Wash tank filters keeps the machine free of excess food soils resulting in cleaner water for longer



## SINGLE PHASE WITH DRAIN PUMP

### SPECIFICATIONS

MODEL	Omniwash Jolly 50 DP
ELECTRICITY	3.75kW, 220V, Single Phase
DIMENSIONS	590 x 600 x 815mm high
WEIGHT	59kg
PC BOARDS	No - Electro Mechanical
MAX GLASS HEIGHT	320mm high
CYCLE TIME	120 seconds
CYCLES PER HOUR	30
HOURLY OUTPUT	Up to 1500 glasses Up to 540 dishes
DRAIN PUMP	Yes - Manual Hold Button
BASKET DIMENSIONS	500 x 500 x 100mm high
BASKETS SUPPLIED	1 x All Purpose / Dish Rack 1 x Open Bowl Dish Rack 1 x Cutlery Holder
BOILER CAPACITY	6Lt
WASH TANK CAPACITY	29Lt
WASH TANK TEMP	55°C
RINSE TEMP	80 ~ 85°C

ORDER CODE

DWO6050



## SINGLE PHASE GRAVITY DRAIN

### SPECIFICATIONS

MODEL	Omniwash Jolly 5000 ST
ELECTRICITY	3.75kW, 220V, Single Phase
DIMENSIONS	590 x 600 x 815mm high
WEIGHT	59kg
PC BOARDS	Yes
MAX GLASS HEIGHT	320mm high
CYCLE TIME	120 seconds
CYCLES PER HOUR	30
HOURLY OUTPUT	Up to 1500 glasses Up to 540 dishes
DRAIN PUMP	No - Gravity Drain
BASKET DIMENSIONS	500 x 500 x 100mm high
BASKETS SUPPLIED	1 x All Purpose / Dish Rack 1 x Open Bowl Dish Rack 1 x Cutlery Holder
BOILER CAPACITY	6Lt
WASH TANK CAPACITY	29Lt
WASH TANK TEMP	55°C
RINSE TEMP	85°C

ORDER CODE

DWO0050



## 3 PHASE GRAVITY DRAIN

### SPECIFICATIONS

MODEL	Omniwash Jolly 50 T
ELECTRICITY	6.75kW, 380V, 3 Phase + N
DIMENSIONS	590 x 600 x 815mm high
WEIGHT	59kg
PC BOARDS	No - Electro Mechanical
MAX GLASS HEIGHT	320mm high
CYCLE TIME	120 seconds
CYCLES PER HOUR	30
HOURLY OUTPUT	Up to 1500 glasses Up to 540 dishes
DRAIN PUMP	No - Gravity Drain
BASKET DIMENSIONS	500 x 500 x 100mm high
BASKETS SUPPLIED	1 x All Purpose / Dish Rack 1 x Open Bowl Dish Rack 1 x Cutlery Holder
BOILER CAPACITY	6Lt
WASH TANK CAPACITY	29Lt
WASH TANK TEMP	55°C
RINSE TEMP	85°C

ORDER CODE

DWO8050



\* WASTE POINT, NOT HIGHER THAN 100mm ABOVE FLOOR LEVEL IS REQUIRED FOR ALL GRAVITY DRAIN MODELS

## OPTIONAL STAND

STAINLESS STEEL WITH BASKET RUNNERS - 600mm high

SDO0050



## FEATURES

- The machine body is manufactured from AISI 304 18/10 stainless steel
- The powerful 1HP wash pump, designed and manufactured by Omniwash, ensures maximum performance wash after wash
- The rinse boiler is fitted with internal baffles to provide consistent clean rinse water and prevents the rinse temperature from dropping off too quickly
- High performance wash arms and jets are designed to work together with the Omniwash wash pump to deliver maximum washing action
- The powerful jets can cut through baked on food soils
- Fitted with easy-to-use illustrated push buttons
- The wash and rinse arms are easy to remove and clean
- Wash tank filters keeps the machine free of excess food soils resulting in cleaner water for longer
- Automatic start by closing of the hood
- Electro mechanical design - no PC board
- Fitted with 4 device levelling legs with plastic feet

## SPECIFICATIONS

MODEL	Omniwash Jolly 6 1P
ELECTRICITY	9.7kW, 380V, 3 Phase + N
DIMENSIONS	635 x 700 x 1460mm high 635 x 700 x 1950mm high (open)
WEIGHT	151kg
PC BOARDS	No - Electro Mechanical
MAX GLASS HEIGHT	430mm high
CYCLE TIME	90 ~ 180 seconds
CYCLES PER HOUR	20 ~ 40
HOURLY OUTPUT	Up to 2000 glasses Up to 700 dishes
DRAIN PUMP	No
BASKET DIMENSIONS	500 x 500 x 100mm high
BASKETS SUPPLIED	(2x) All Purpose / Plate Dish Rack (1x) Open Bowl Dish Rack (1x) Cutlery Holder
BOILER CAPACITY	9Lt
WASH TANK CAPACITY	55Lt
WASH TANK TEMP	55°C
RINSE TEMP	80 ~ 85°C

**ORDER CODE**                      **DWO1009**



**\* WASTE POINT, NOT HIGHER THAN 100mm ABOVE FLOOR LEVEL IS REQUIRED FOR ALL GRAVITY DRAIN MODELS**

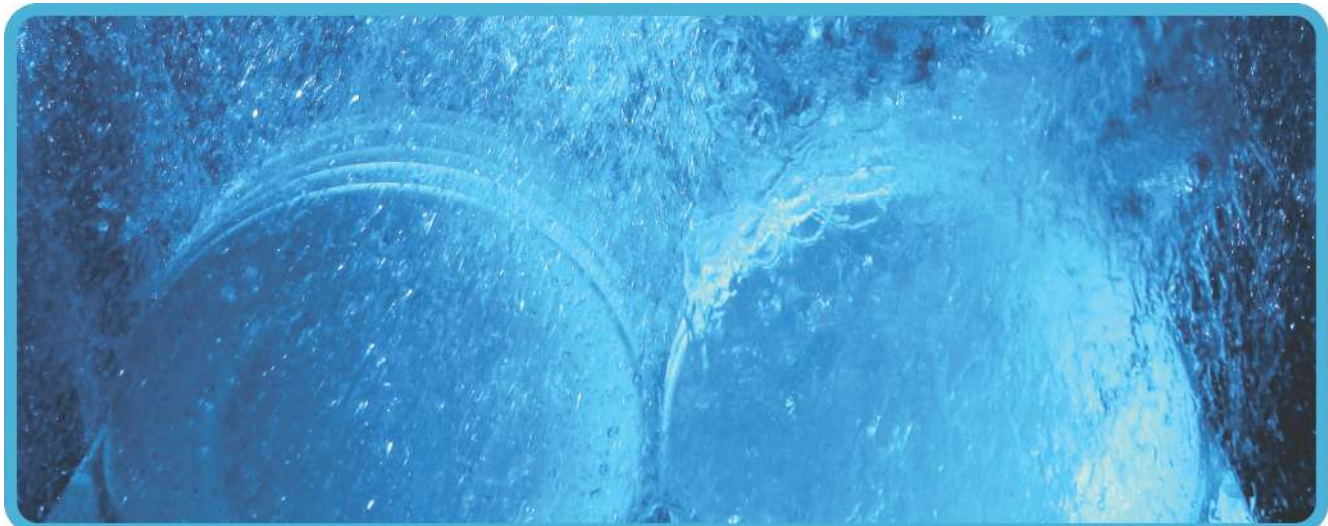



## FEATURES

- AISI 304 Stainless steel body
- Ergonomic design
- Easy to use electro mechanical control panel
- 4.5 kW boiler resistance provides the fixed 82.5 °C water temperature level for the best washing results
- Specially designed wash and rinse spraying arm provides the best washing results
- Adjustable wash programs. 60, 90, 120 or 180 seconds
- Specially designed rubber water transfer system, prevents pressure loss and provides more effective washing



## SINGLE PHASE WITH DRAIN & DETERGENT PUMPS SPECIFICATIONS

MODEL	Crystal CRW500 TPD
ELECTRICITY	5.2kW, 220V, Single Phase
DIMENSIONS	590 x 610 x 830mm high
WEIGHT	60kg
PC BOARDS	No - Electro Mechanical
MAX GLASS HEIGHT	320mm high
CYCLE TIME	60 ~ 180 seconds
CYCLES PER HOUR	20 ~ 60
HOURLY OUTPUT	Up to 1500 glasses Up to 540 dishes
DRAIN PUMP	Yes
RINSE & CHEM PUMP	Yes
BASKET DIMENSIONS	500 x 500 x 100mm high
BASKETS SUPPLIED	1 x All Purpose / Dish Rack 1 x Open Bowl Dish Rack 1 x Cutlery Holder
BOILER CAPACITY	6Lt
WASH TANK CAPACITY	14Lt
WASH TANK TEMP	55°C
RINSE TEMP	80 ~ 85°C
<b>ORDER CODE</b>	<b>CRY-CRW500.TPD</b>

## SINGLE PHASE WITH DRAIN PUMP SPECIFICATIONS

MODEL	Crystal CRW500 T
ELECTRICITY	5.2kW, 220V, Single Phase
DIMENSIONS	590 x 610 x 830mm high
WEIGHT	60kg
PC BOARDS	No - Electro Mechanical
MAX GLASS HEIGHT	320mm high
CYCLE TIME	60 ~ 180 seconds
CYCLES PER HOUR	20 ~ 60
HOURLY OUTPUT	Up to 1500 glasses Up to 540 dishes
DRAIN PUMP	Yes
RINSE & CHEM PUMP	No
BASKET DIMENSIONS	500 x 500 x 100mm high
BASKETS SUPPLIED	1 x All Purpose / Dish Rack 1 x Open Bowl Dish Rack 1 x Cutlery Holder
BOILER CAPACITY	6Lt
WASH TANK CAPACITY	14Lt
WASH TANK TEMP	55°C
RINSE TEMP	80 ~ 85°C
<b>ORDER CODE</b>	<b>CRY-CRW500.T</b>

## OPTIONAL STAND

STAINLESS STEEL WITH BASKET RUNNERS - 600mm high

SDO0050





## FEATURES

- AISI 304 Stainless steel body with esthetic finish
- Ergonomic design with rounded corners
- Easy to use electro mechanical control panel
- Specially designed hood spring system
- 9.7kW boiler resistance provides the fixed 82.5°C water temperature level for the best washing results
- Specially designed wash and rinse spraying arm provides the best washing results
- 2 cycles - 90 or 180 seconds
- Specially designed rubber water transfer system, prevents pressure loss and provides more effective washing

## SPECIFICATIONS

ELECTRICITY	9.7kW, 380V, 3 Phase + N
DIMENSIONS	610 x 730 x 1460mm high 610 x 730 x 1950mm high (open)
WEIGHT	95kg
MAX GLASS HEIGHT	380mm high
CYCLE TIME	90 ~ 180 seconds
CYCLES PER HOUR	20 ~ 40
HOURLY OUTPUT	Up to 2000 glasses Up to 700 dishes
BASKET DIMENSIONS	500 x 500 x 100mm high
BASKETS SUPPLIED	(1x) All Purpose / Plate Dish Rack (1x) Open Bowl Dish Rack
BOILER CAPACITY	7Lt
WASH TANK CAPACITY	45Lt
WASH TANK TEMP	55°C
RINSE TEMP	80 ~ 85°C

## GRAVITY DRAIN

MODEL	Crystal CRW1000
DRAIN PUMP	No
RINSE & CHEM PUMP	No
ORDER CODE	<b>CRY-CRW1000</b>

## DRAIN PUMP

MODEL	Crystal CRW1000 T
DRAIN PUMP	Yes
RINSE & CHEM PUMP	No
ORDER CODE	<b>CRY-CRW1000.T</b>

## DETERGENT PUMPS

MODEL	Crystal CRW1000 PD
DRAIN PUMP	No
RINSE & CHEM PUMP	Yes
ORDER CODE	<b>CRY-CRW1000.PD</b>

## DRAIN & DETERGENT PUMPS

MODEL	Crystal CRW1000 TPD
DRAIN PUMP	Yes
RINSE & CHEM PUMP	Yes
ORDER CODE	<b>CRY-CRW1000.TPD</b>



\* WASTE POINT, NOT HIGHER THAN 100mm ABOVE FLOOR LEVEL IS REQUIRED FOR ALL GRAVITY DRAIN MODELS



## FEATURES

- AISI 304 stainless steel body and digital control panel
- Instant display of tank and boiler water temperatures
- 5 different washing programs, adjustable to 60-90-120-180-240 seconds
- 1 dishwashing basket consumes 3 liters of water
- EPDM rubber hose substance conforming to Food Codex standards
- Effective washing results with a specially designed washing and rinsing arms structure
- Thanks to a specially-designed card technology, the rinsing process does not start before the boiler water temperature reaches 85°C. This guarantees hygienic rinsing according to HACCP standards
- Automatic pause and resume feature when opening or closing the door
- 9 kW boiler heating element, 4,5 kW tank heating element
- Front cover allows easy technical service without moving / dragging the product around

## DIGITAL CONTROL

### SPECIFICATIONS

MODEL	Crystal CRWD1000
ELECTRICITY	9.7kW, 380V, 3 Phase + N
DIMENSIONS	610 x 730 x 1460mm high 610 x 730 x 1950mm high (open)
WEIGHT	95kg
MAX GLASS HEIGHT	380mm high
CYCLE TIME	60 ~ 240 seconds
CYCLES PER HOUR	15 ~ 60
HOURLY OUTPUT	Up to 2000 glasses Up to 1000 dishes
BASKET DIMENSIONS	500 x 500mm
BASKETS SUPPLIED	(1x) All Purpose / Plate Dish Rack (1x) Open Bowl Dish Rack
BOILER CAPACITY	7Lt
WASH TANK CAPACITY	45Lt
WASH TANK TEMP	55°C
RINSE TEMP	80 ~ 85°C

**ORDER CODE**

**CRY-CRWD1000**

**\* WASTE POINT, NOT HIGHER THAN 100mm ABOVE FLOOR LEVEL IS REQUIRED FOR ALL GRAVITY DRAIN MODELS**



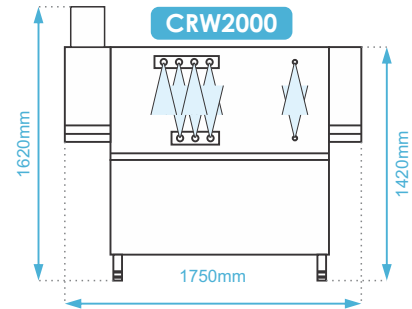

## FEATURES

- AISI 304 stainless steel body
- Easy to remove and install, wide-angle spray stainless steel wash and rinse arms that dispense the water evenly to cover all your dishes and cutlery, ensuring a thorough clean
- AISI 304 stainless steel drying fan and module, making it possible to quickly reuse the dishes
- Thanks to an easy-to-use control panel, all functions are controlled by just two buttons
- Safety system prevents the door from collapsing and allows safe operation during washing
- PE1000 plastic parts (used on the door and conveyor mechanisms) are resistant to abrasion, prevent bacteria accumulation and conform to Food Codex standards
- Heat-resistant, double-deck curtains produced by a seamless joining method to comply with hygiene standards, prevent heat and water loss and can be easily cleaned and removed
- Non-return valve system
- Pressure reducer protects the dosing pumps against high water pressure and can be adjusted to the desired pressure
- Dosing pump electrical connection panel is designed for all brands and models
- Energy saving provided by heat insulation in boilers and washing tank
- Design that allows easy technical service without moving / dragging the product around
- Door safety sensor
- Inlet and rinse sensors save energy, water and chemical consumption
- Conveyor anti-jam safety system
- Limit switch fitted to end of outlet table
- Machine height can be adjusted with stainless steel feet

## SPECIFICATIONS

ELECTRICITY	40.5kW, 380V, 3 Phase + N
DIMENSIONS	1750 x 780 x 1620mm high
WEIGHT	270kg
CYCLES PER HOUR	110
HOURLY OUTPUT	Up to 2000 dishes
BASKET DIMENSIONS	500 x 500mm
BOILER CAPACITY	23Lt
WASH TANK CAPACITY	100Lt
WASH TANK TEMP	55 ~ 60°C
RINSE TEMP	82 ~ 85°C



### LEFT TO RIGHT

MODEL Crystal CRW2000-R  
**ORDER CODE CRY-CRW2000L-R**

### RIGHT TO LEFT

MODEL Crystal CRW2000-L  
**ORDER CODE CRY-CRW2000R-L**



**Conveyor units with dryer and pre-wash modules available on request**



## PRE-RINSE SPRAYS



### DECK MOUNTED

#### FEATURES

- Single hole deck mount mixing faucet
- 13mm BSPP in-line check valves
- Quarter-turn ceramic cartridges with lever handles and colour coded screws
- Supplied with (2x) 455mm flexible hoses
- 1.1m flex hose with overhead spring
- 5 SV 1.15 GPM spray valve
- Includes 152mm wall bracket

MODEL T&S 5PR-2S00  
ORDER CODE PRS/5PR-2S00

### WALL MOUNTED

#### FEATURES

- 203mm wall mount mixing faucet
- In-line check valves
- 13mm NPT female inlets
- Quarter-turn ceramic cartridges with lever handles and colour coded screws
- 1.1m flex hose with overhead spring
- 5 SV 1.15 GPM spray valve
- Includes 152mm wall bracket

MODEL T&S 5PR-8W00  
ORDER CODE PRS/5PR-8W00



## OPTIONAL SWIVEL ARM FAUCET

MODEL T&S 5AFL12  
ORDER CODE PRS/5AFL12

## KITCHEN FAUCETS



#### FEATURES

- Wall mount faucet
- Distance between inlets: 150mm / 6"
- Quarter-turn ceramic cartridges with lever handles and colour coded screws
- 13mm NPT female inlets

MODEL T&S 5F-6WLX12  
ORDER CODE WMF/5F-6WLX12



## FEATURES

- Open hose reel (Stainless steel or epoxy coated)
- 3/8" heavy-duty non-marking hose rated to 300psi
- 3/8" NPT female inlet
- Multi-fit bracket for wall, ceiling or under counter mounting
- Stainless steel front trigger watergun with swivel action
- Ratcheting system with activated retraction
- Adjustable hose bumper / stopper



## 10 METER - STAINLESS STEEL REEL

### SPECIFICATIONS

MODEL	T&S Brass B-7132-05
HOSE LENGTH	10m
HOSE DIAMETER	9.5mm
WEIGHT	18kg
MAX PRESSURE	125psi
TEMPERATURE RANGE	4 ~ 90°C

ORDER CODE                    **HRT/B-7132-05**



## 10 METER - EPOXY COATED REEL

### SPECIFICATIONS

MODEL	T&S Brass B-7232-05
HOSE LENGTH	10m
HOSE DIAMETER	9.5mm
WEIGHT	18kg
MAX PRESSURE	125psi
TEMPERATURE RANGE	4 ~ 90°C

ORDER CODE                    **HRT/B-7232-05**



# KNEE OPERATED HAND WASH BASIN



## FEATURES

- Manufactured from AISI 304 stainless steel
- High splash-back with deep-drawn tank
- Hot and cold water supply
- Adjustable single lever mixertap with non-return valve
- Fitted with a "swan-neck" faucet
- Smooth rounded corners for increased esthetics

## SPECIFICATIONS

MODEL	SmartChef WT-C400401
DIMENSIONS	400 x 330 x 570mm high
WEIGHT	7kg

ORDER CODE                    **HWS0001**

## LAUNDRY TROLLEY

### FEATURES

- Frame manufactured from 25mm stainless steel tubing
- High quality canvas bag included
- (10x) Metal clasp hooks to secure canvas bag to frame
- Easy to assemble (*Supplied flatpacked*)
- Fitted with (4x) castors (2x) lockable



### SPECIFICATIONS

MODEL	SmartChef 130201
DIMENSIONS	910 x 560 x 920mm high
BAG DIMENSIONS	850 x 550 x 600mm high
WEIGHT	8kg
LOADING CAPACITY	150kg

ORDER CODE **LDT0001**



**HIGH QUALITY CANVAS BAG**

## JANITOR TROLLEY

### FEATURES

- Manufactured from polypropylene plastic
- Supplied with (1x) 60Lt PVC bag
- 3 Sturdy shelves plus built-in mop, broom holders and hooks to keep things organized
- Spacious front platform is large enough to hold an additional trash can or mop bucket and wringer
- Easy to assemble (*Supplied flatpacked*)
- Fitted with (2x) 80mm front wheels and (2x) 200mm rear wheels



### SPECIFICATIONS

MODEL	SmartChef 600503
DIMENSIONS	1250 x 510 x 950mm high
WEIGHT	12kg

ORDER CODE **JTP0001**



**CONVENIENCE**



**inoxserv**

LUXERIOUS BUFFET WARE

CHAFING DISHES • SOUP STATIONS • CEREAL DISPENSERS • JUICE DISPENSERS • URNS

## SECTION INDEX

Cereal dispensers .....	125
Chafing dish heat elements .....	119
Chafing dish stands .....	118-119
<i>Chafing dishes</i>	
• Econo series .....	121
• Induction series .....	118-119
• PC cover series .....	122
• Window series .....	121
Deluxe coffee urns .....	127
Heat elements for chafing dishes .....	119
Hot water urns .....	127
Induction chafing dishes .....	118-119
Induction warmers .....	120
Inserts .....	123
Juice dispensers .....	126
Soup kettles .....	121, 124
Soup warmers .....	119
Urns .....	127



# CHAFING DISHES

## INDUCTION SERIES

**inoxserv**

### REMOVABLE LID WITH TRANSPARENT GLASS

- It provides a clear view of food, even when closed
- It is easy to open and it engages at various opening angles
- It is easy to remove for cleaning and storage
- The lid movement is controlled by a long-life damping hinge
- It provides a water internal recycle system around the lid edge



REMOVABLE LID



INDUCTION HEATING

### HEAT SOURCES

- **Induction cooker** - Table top - Counter sunk - In stand
- **Electric heater** - In stand
- **Solid alcohol** - In stand



CAPSULATED BOTTOM

### CAPSULATED BOTTOM

- Provides even heat distribution
- Minimises heat loss improving energy efficiency



\*SHOWN WITH OPTIONAL STAND



\*SHOWN WITH OPTIONAL STAND

### CHAFING DISH WITH HYDRAULIC GLASS LID RECTANGULAR

#### SPECIFICATIONS

MODEL	Inoxserv Induction Series S60593
DIMENSIONS	580 x 440 x 330mm high
CAPACITY	8.5Lt
HEAT SOURCE	Induction cooker Heating element Chafing fuel
SUPPLIED WITH	(1x) 1/1GN pan - 65mm deep Serving spoon holder
ORDER CODE	<b>BEI-S60593</b>

\*STAND AND HEAT SOURCE NOT INCLUDED



### CHAFING DISH WITH HYDRAULIC GLASS LID SQUARE

#### SPECIFICATIONS

MODEL	Inoxserv Induction Series S60293
DIMENSIONS	400 x 440 x 320mm high
CAPACITY	4.8Lt
HEAT SOURCE	Induction cooker Heating element Chafing fuel
SUPPLIED WITH	(1x) 2/3 GN pan - 65mm deep Serving spoon holder
ORDER CODE	<b>BEI-S60293</b>

\*STAND AND HEAT SOURCE NOT INCLUDED



### STAND FOR CHAFING DISH - RECTANGULAR

#### SPECIFICATIONS

MODEL	Inoxserv Induction Series S60590
DIMENSIONS	565 x 330 x 155mm high
HEAT SOURCE	Induction cooker > ISC-BT-70T Heating element > BEI-S305T Chafing fuel
SUPPLIED WITH	(2x) Chafing fuel holders
ORDER CODE	<b>BEI-S60590</b>

\*HEAT SOURCE NOT INCLUDED



### STAND FOR CHAFING DISH - SQUARE

#### SPECIFICATIONS

MODEL	Inoxserv Induction Series S60290
DIMENSIONS	385 x 385 x 155mm high
HEAT SOURCE	Induction cooker > ISC-BT-70T Heating element > BEI-S305T Chafing fuel
SUPPLIED WITH	(1x) Chafing fuel holders
ORDER CODE	<b>BEI-S60290</b>

\*HEAT SOURCE NOT INCLUDED



## CHAFING DISHES INDUCTION SERIES



\*SHOWN WITH OPTIONAL STAND

### CHAFING DISH WITH HYDRAULIC GLASS LID ROUND

#### SPECIFICATIONS

MODEL	Inoxserv Induction Series S50293
DIMENSIONS	440 x 480 x 320mm high
CAPACITY	5Lt
HEAT SOURCE	Induction cooker Heating element Chafing fuel
SUPPLIED WITH	(1x) Round pan - 65mm deep Serving spoon holder
ORDER CODE	<b>BEI-S50293</b>

\*STAND AND HEAT SOURCE NOT INCLUDED



### STAND FOR CHAFING DISH - ROUND

#### SPECIFICATIONS

MODEL	Inoxserv Induction Series S50280
DIMENSIONS	300 x 300 x 155mm high
HEAT SOURCE	Induction cooker > ISC-BT-70T Heating element > BEI-S205T Chafing fuel
SUPPLIED WITH	(1x) Chafing fuel holders
ORDER CODE	<b>BEI-S50280</b>

\*HEAT SOURCE NOT INCLUDED



# inoxserv



\*SHOWN WITH OPTIONAL STAND

### SOUP STATION WITH HYDRAULIC GLASS LID

#### SPECIFICATIONS

MODEL	Inoxserv Induction Series S50288
DIMENSIONS	410 x 490 x 410mm high
CAPACITY	10Lt
HEAT SOURCE	Induction cooker Heating element Chafing fuel
SUPPLIED WITH	(1x) Round pan - 210mm deep Serving spoon holder
ORDER CODE	<b>BEI-S50288</b>

\*STAND AND HEAT SOURCE NOT INCLUDED



### STAND FOR BUFFET SOUP STATION

#### SPECIFICATIONS

MODEL	Inoxserv Induction Series S50290
DIMENSIONS	315 x 315 x 155mm high
HEAT SOURCE	Induction cooker > ISC-BT-70T Heating element > BEI-S205T Chafing fuel
SUPPLIED WITH	(1x) Chafing fuel holders
ORDER CODE	<b>BEI-S50290</b>

\*HEAT SOURCE NOT INCLUDED



### HEATING ELEMENT WITH CONTROLLER - 250mm

#### SPECIFICATIONS

MODEL	Inoxserv S305T
ELECTRICITY	0.38kW, 230V, Single Phase
DIMENSIONS	250 x 200mm
COMPATIBLE WITH	Oblong - BEI-S60590 Square - BEI-S60290
ORDER CODE	<b>BEI-S305T</b>



### HEATING ELEMENT WITH CONTROLLER - 175mm

#### SPECIFICATIONS

MODEL	Inoxserv S205T
ELECTRICITY	0.33kW, 230V, Single Phase
DIMENSIONS	175 x 200mm
COMPATIBLE WITH	Round - BEI-S50280 Soup Station - BEI-S50290
ORDER CODE	<b>BEI-S205T</b>



## DROP IN / COUNTERSUNK MODELS - TOUCH CONTROL



### SPECIFICATIONS

MODEL SmartChef-i BT-200T1  
 ELECTRICITY 2kW, 230V, Single Phase  
 DIMENSIONS 375 x 305 x 75mm high  
 TEMPERATURE RANGE 60°C ~ 240°C  
 COMPATIBLE WITH BEI-S60593  
 BEI-S60293  
 BEI-S50293  
 BEI-S50288

ORDER CODE **ISC-BT-200T1**

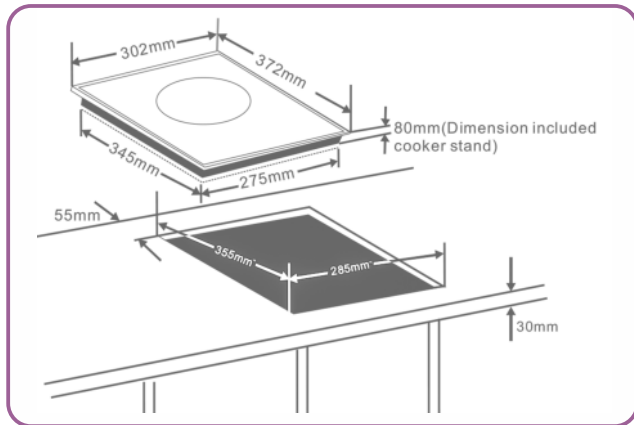

### SPECIFICATIONS

MODEL SmartChef-i BT-100T  
 ELECTRICITY 2kW, 230V, Single Phase  
 DIMENSIONS 245 x 245 x 60mm high  
 TEMPERATURE RANGE 60°C ~ 240°C  
 COMPATIBLE WITH BEI-S60593  
 BEI-S60293  
 BEI-S50293  
 BEI-S50288

ORDER CODE **ISC-BT-100T**

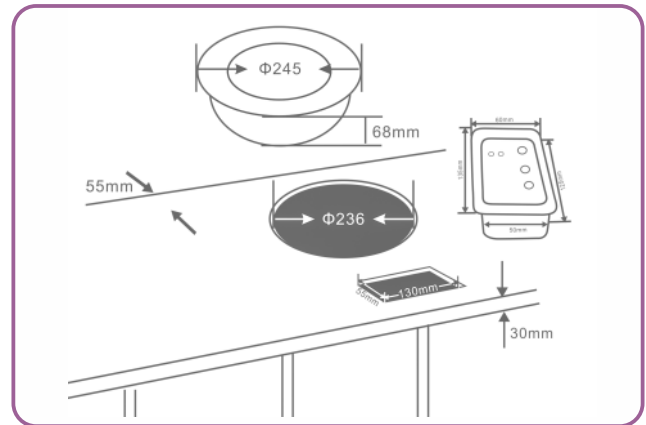

## TABLE TOP MODEL - MANUAL CONTROL



### SPECIFICATIONS

MODEL SmartChef-i BF-100A  
 ELECTRICITY 1kW, 230V, Single Phase  
 DIMENSIONS 315 x 460 x 60mm high  
 TEMPERATURE RANGE 60°C ~ 240°C  
 COMPATIBLE WITH BEI-S60593  
 BEI-S60293  
 BEI-S50293  
 BEI-S50288

ORDER CODE **ISC-BF-100A**

## IN-STAND MODEL - TOUCH CONTROL



### SPECIFICATIONS

MODEL SmartChef-i BT-70T  
 ELECTRICITY 1kW, 230V, Single Phase  
 DIMENSIONS 180 x 180 x 70mm high  
 TEMPERATURE RANGE 60°C ~ 240°C  
 COMPATIBLE WITH BEI-S60590  
 BEI-S60290  
 BEI-S50290  
 BEI-S50280

ORDER CODE **ISC-BT-70T**



## CHAFING DISHES WINDOW / ECONOMIC SERIES

**inoxserv**



\*HEAT SOURCE NOT INCLUDED

### CHAFING DISH WITH SHOW WINDOW - RECTANGULAR SPECIFICATIONS

MODEL Inoxserv Show Window Series KS61363-2  
DIMENSIONS 645 x 475 x 435mm high  
CAPACITY 8.5Lt  
HEAT SOURCE Chafing fuel  
SUPPLIED WITH (2x) 1/2GN pans - 65mm deep  
Stand  
(2x) Chafing fuel holders

ORDER CODE

**BEI-KS61363-2**



\*HEAT SOURCE NOT INCLUDED

### CHAFING DISH WITH SHOW WINDOW - ROUND SPECIFICATIONS

MODEL Inoxserv Show Window Series KS51363  
DIMENSIONS 500 x 530 x 450mm high  
CAPACITY 5Lt  
HEAT SOURCE Chafing fuel  
SUPPLIED WITH (1x) Round pan - 65mm deep  
Stand  
(1x) Chafing fuel holder

ORDER CODE

**BEI-KS51363**



\*HEAT SOURCE NOT INCLUDED

### CHAFING DISH - RECTANGULAR SPECIFICATIONS

MODEL Inoxserv Economic Series AT61363-2  
DIMENSIONS 645 x 475 x 435mm high  
CAPACITY 8.5Lt  
HEAT SOURCE Chafing fuel  
SUPPLIED WITH (2x) 1/2GN pans - 65mm deep  
Stand  
(2x) Chafing fuel holders

ORDER CODE

**BEI-AT61363-2**



\*HEAT SOURCE NOT INCLUDED

### CHAFING DISH - ROUND SPECIFICATIONS

MODEL Inoxserv Economic Series AT51363  
DIMENSIONS 500 x 530 x 450mm high  
CAPACITY 5Lt  
HEAT SOURCE Chafing fuel  
SUPPLIED WITH (1x) Round pan - 65mm deep  
Stand  
(1x) Chafing fuel holder

ORDER CODE

**BEI-AT51363**



### SOUP KETTLE SPECIFICATIONS

MODEL Inoxserv Economic Series AT51388  
ELECTRICITY 230V, Single Phase  
DIMENSIONS 330 x 330mm high  
CAPACITY 9Lt  
SUPPLIED WITH (1x) Round pan - 200mm deep

ORDER CODE

**BEI-AT51388**

**FEATURES**

- Stainless steel body
- Stainless steel pan
- Polycarbonate roll-top cover

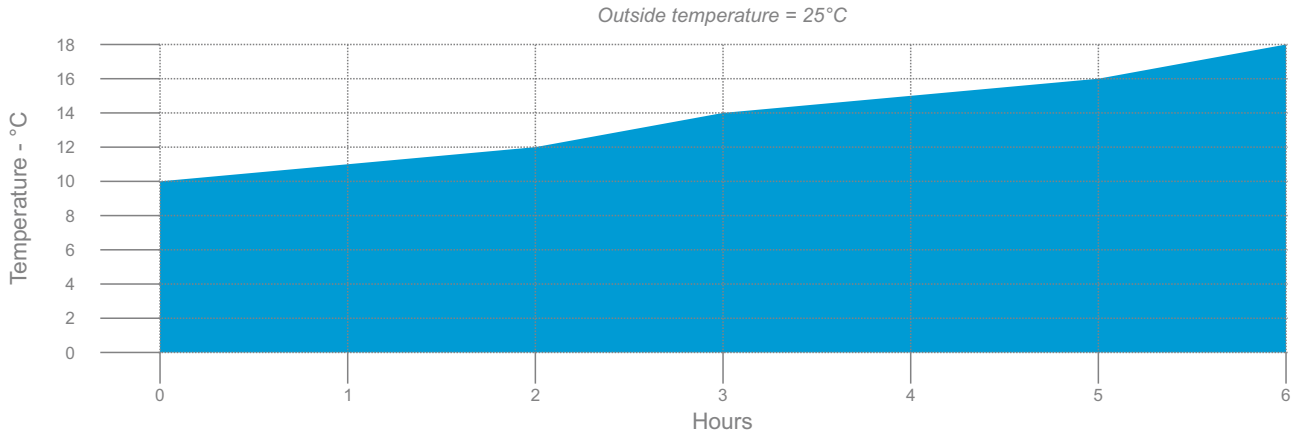

**NEUTRAL DISPLAY**

**SPECIFICATIONS**

MODEL: Inoxserv KS62160-1  
 DIMENSIONS: 490 x 410 x 410mm high  
 PAN DIMENSIONS: 475 x 270 x 60mm deep

ORDER CODE: **BEI-KS62160-1**



**HEATED DISPLAY**

**SPECIFICATIONS**

MODEL: Inoxserv SK62160-1  
 ELECTRICITY: 1kW, 230V, Single Phase  
 DIMENSIONS: 490 x 410 x 410mm high  
 PAN DIMENSIONS: 475 x 270 x 60mm deep

ORDER CODE: **BEI-SK62160-1**



**COLD DISPLAY**

**SPECIFICATIONS**

MODEL: Inoxserv SC62140-1  
 DIMENSIONS: 490 x 410 x 410mm high  
 PAN DIMENSIONS: 475 x 270 x 40mm deep  
 SUPPLIED WITH: (2x) Freezer packs

ORDER CODE: **BEI-SC62140-1**

## FEATURES

- Manufactured from 0.8mm heavy duty stainless steel
- Rounded edges
- Anti-Jam system
- Reinforced corners



## FULL INSERT SPECIFICATIONS

DIMENSIONS 325 x 530 x 20mm deep  
CAPACITY 2.5Lt  
ORDER CODE **GNF8020**

DIMENSIONS 325 x 530 x 55mm deep  
CAPACITY 7.5Lt  
ORDER CODE **GNF8055**

DIMENSIONS 325 x 530 x 65mm deep  
CAPACITY 9Lt  
ORDER CODE **GNF8065**



## 1/2 INSERT SPECIFICATIONS

DIMENSIONS 325 x 256 x 65mm deep  
CAPACITY 4Lt  
ORDER CODE **GNH8065**



## 2/3 INSERTS SPECIFICATIONS

DIMENSIONS 325 x 352 x 20mm deep  
CAPACITY 1.5Lt  
ORDER CODE **GN2T8020**

DIMENSIONS 325 x 352 x 65mm deep  
CAPACITY 5.5Lt  
ORDER CODE **GN2T8065**



## 1/3 INSERT SPECIFICATIONS

DIMENSIONS 325 x 176 x 40mm deep  
CAPACITY 1.5Lt  
ORDER CODE **GNT8040**

DIMENSIONS 325 x 176 x 65mm deep  
CAPACITY 2.5Lt  
ORDER CODE **GNT8065**





**FEATURES**

- Available in black or Stainless steel
- Stainless steel base (powder coated/polished)
- 304 stainless steel seamless insert
- Temperature control via thermostat
- Fitted with a hinged lid
- Fitted with non-slip feet

**SPECIFICATIONS**

ELECTRICITY	0.4kW, 220V, Single Phase
DIMENSIONS	Ø 330mm x 380mm high
WEIGHT	4Kg
TEMPERATURE RANGE	0 ~ 95°C
CAPACITY	10Lt

**BLACK**

MODEL	Inoxserve 83010SP
ORDER CODE	SKI0010

**STAINLESS STEEL**

MODEL	Inoxserve 81010SP
ORDER CODE	SKI1010

**POWDER  
COATED  
STAINLESS  
STEEL BASE**

**TEMP.  
CONTROL  
(0 ~ 95°C)**

**NON  
SLIP  
FEET**

**HINGED  
STAINLESS  
STEEL LID**

**304  
STAINLESS  
STEEL  
INSERT**



## CEREAL DISPENSERS

**inoxserv**



### CEREAL DISPENSER - DOUBLE LEVER PORTION CONTROL

#### SPECIFICATIONS

MODEL Inoxserv AT90123-2  
DIMENSIONS 420 x 450 x 620mm high  
CAPACITY (2x) 7Lt

ORDER CODE BEI-AT90123-2



### CEREAL DISPENSER - SINGLE LEVER PORTION CONTROL

#### SPECIFICATIONS

MODEL Inoxserv AT90123  
DIMENSIONS 420 x 230 x 620mm high  
CAPACITY 7Lt

ORDER CODE BEI-AT90123



### CEREAL DISPENSER - DOUBLE ROTATION PORTION CONTROL

#### SPECIFICATIONS

MODEL Inoxserv AT90133-2  
DIMENSIONS 380 x 480 x 660mm high  
CAPACITY (2x) 9Lt

ORDER CODE BEI-AT90133-2



### CEREAL DISPENSER - SINGLE ROTATION PORTION CONTROL

#### SPECIFICATIONS

MODEL Inoxserv AT90133  
DIMENSIONS 360 x 230 x 660mm high  
CAPACITY 9Lt

ORDER CODE BEI-AT90133



STAINLESS STEEL

**DOUBLE - STAINLESS STEEL**

**SPECIFICATIONS**

MODEL Inoxserv AT90212-2  
 DIMENSIONS 365 x 450 x 535mm high  
 CAPACITY (2x) 7Lt  
 SUPPLIED WITH (2x) Freezer packs

ORDER CODE BEI-AT90212-2



BEACH WOOD

**DOUBLE - BEACH WOOD**

**SPECIFICATIONS**

MODEL Inoxserv AT90315-2  
 DIMENSIONS 350 x 450 x 580mm high  
 CAPACITY (2x) 7Lt  
 SUPPLIED WITH (2x) Freezer packs

ORDER CODE BEI-AT90315-2



**SINGLE - STAINLESS STEEL**

**SPECIFICATIONS**

MODEL Inoxserv AT90212  
 DIMENSIONS 365 x 230 x 535mm high  
 CAPACITY 7Lt  
 SUPPLIED WITH (1x) Freezer pack

ORDER CODE BEI-AT90212



**SINGLE - BEACH WOOD**

**SPECIFICATIONS**

MODEL Inoxserv AT90315  
 DIMENSIONS 350 x 230 x 580mm high  
 CAPACITY 7Lt  
 SUPPLIED WITH (1x) Freezer pack

ORDER CODE BEI-AT90315



**JUICE DISPENSER - DOUBLE WITH CENTRE ICE TUBE**

**SPECIFICATIONS**

MODEL Inoxserv AT90512-2  
 DIMENSIONS 350 x 540 x 580mm high  
 CAPACITY (2x) 8Lt

ORDER CODE BEI-AT90512-2



**JUICE DISPENSER - SINGLE WITH CENTRE ICE TUBE**

**SPECIFICATIONS**

MODEL Inoxserv AT90512  
 DIMENSIONS 350 x 260 x 580mm high  
 CAPACITY 8Lt

ORDER CODE BEI-AT90512



# BEVERAGE DISPENSERS COLD / HOT

**inoxserv**



*\*HEAT SOURCE NOT INCLUDED*

## FEATURES

- The body is manufactured from Polycarbonate plastic, heat resistant up to 120 C
- Conveniently placed handles with removable stainless steel base for easy refilling
- Fitted with a stainless steel centre ice tube
- High polish stainless steel lid
- Fuel holder not included

## 12 LITRE - WITH CENTRE ICE TUBE

### SPECIFICATIONS

MODEL	Inoxserv AT90012
DIMENSIONS	350 x 310 x 500mm high
CAPACITY	12Lt
HEAT SOURCE	Induction warmer Chafing fuel

ORDER CODE **BEI-AT90012**

# DELUXE HOT WATER URNS

**inoxserv**

## FEATURES

- Full stainless steel construction
- Conveniently placed handles with removable stainless steel base for easy refilling
- High polish finish
- Fuel holder not included



*\*HEAT SOURCE NOT INCLUDED*

## 19 LITRE

### SPECIFICATIONS

MODEL	Inoxserv AT80019
DIMENSIONS	350 x 310 x 620mm high
CAPACITY	19Lt
HEAT SOURCE	Induction warmer Chafing fuel

ORDER CODE **BEI-AT80019**



*\*HEAT SOURCE NOT INCLUDED*

## 12 LITRE

### SPECIFICATIONS

MODEL	Inoxserv AT80012
DIMENSIONS	350 x 310 x 500mm high
CAPACITY	12Lt
HEAT SOURCE	Induction warmer Chafing fuel

ORDER CODE **BEI-AT80012**



**POLAR CAB**

**MORE THAN JUST  
REFRIGERATION...**



**FRIDGES ❄️ FREEZERS ❄️ COOLERS ❄️ ICE MACHINES...**



# REFRIGERATION

## SECTION INDEX

Back bar coolers .....	135
Blast chillers .....	134
Chef bases .....	139
Display fridges .....	132
Freezers	
• Display freezers .....	132-137
• Ice cream scoop freezers .....	148-149
• Upright storage freezers .....	130-132
Fridges	
• Back bar coolers .....	135
• Display fridges .....	132
• Pizza ingredient fridges .....	136
• Saladette cabinets .....	136-138
• Upright storage fridges .....	130-132
Gelato machines .....	144
Ice cream scoop freezers .....	148-149
Ice machines	
• Modular .....	140-141
• Self-contained .....	142-143
Pizza ingredient fridges .....	136, 165
Saladette cabinets .....	136-138
Soft serve machines .....	145-147
Upright freezers .....	130-132
Upright fridges .....	130-132



### FEATURES

- Exterior and interior stainless steel body (AISI304)
- Air managing system - provides inside refrigeration balance
- Lockable, reversible and self closing doors
- 20 level embossed guides for shelves or GN containers
- Auto defrost with heating element
- CFC free, high pressure injected polyurethane insulation
- High class energy saving design
- Hygienic and ergonomic interior custom design
- Ventilated air chamber with interior LED lighting



### DOUBLE DOOR FRIDGE

#### SPECIFICATIONS

MODEL	Crystal ECO 1400S
ELECTRICITY	0.5kW, 230V, Single Phase
DIMENSIONS	1400 x 840 x 2060mm high
WEIGHT	175kg
INTERNAL DIMENSIONS	1240 x 690 x 1950mm high
CAPACITY	1250Lt
RUNNER SPACING	50mm
GRIDS SUPPLIED	(6x) 530 x 630mm
TEMPERATURE RANGE	2 ~ 8°C
REFRIGERANT GAS	R134a

ORDER CODE

CRY-ECO-E1400S



### SINGLE DOOR FRIDGE

#### SPECIFICATIONS

MODEL	Crystal ECO 700S
ELECTRICITY	0.25kW, 230V, Single Phase
DIMENSIONS	700 x 840 x 2060mm high
WEIGHT	122kg
INTERNAL DIMENSIONS	620 x 690 x 1950mm high
CAPACITY	600Lt
RUNNER SPACING	50mm
GRIDS SUPPLIED	(3x) 530 x 630mm
TEMPERATURE RANGE	2 ~ 8°C
REFRIGERANT GAS	R134a

ORDER CODE

CRY-ECO-E700S



### DOUBLE DOOR FREEZER ❄️

#### SPECIFICATIONS

MODEL	Crystal ECO 1400D
ELECTRICITY	0.87kW, 230V, Single Phase
DIMENSIONS	1400 x 840 x 2060mm high
WEIGHT	177kg
INTERNAL DIMENSIONS	1240 x 690 x 1950mm high
CAPACITY	1250Lt
RUNNER SPACING	50mm
GRIDS SUPPLIED	(6x) 530 x 630mm
TEMPERATURE RANGE	-22 ~ -10°C
REFRIGERANT GAS	R134a

ORDER CODE

CRY-ECO-E1400D



### SINGLE DOOR FREEZER ❄️

#### SPECIFICATIONS

MODEL	Crystal ECO 700D
ELECTRICITY	0.55kW, 230V, Single Phase
DIMENSIONS	700 x 840 x 2060mm high
WEIGHT	125kg
INTERNAL DIMENSIONS	620 x 690 x 1950mm high
CAPACITY	600Lt
RUNNER SPACING	50mm
GRIDS SUPPLIED	(3x) 530 x 630mm
TEMPERATURE RANGE	-22 ~ -10°C
REFRIGERANT GAS	R134a

ORDER CODE

CRY-ECO-E700D



### OPTIONAL EXTRAS

#### GRIDS

2/1 GN GRIDS	530 x 630mm
ORDER CODE	OGS0021

#### SHELF RUNNERS

LEFT SIDE	YECO-YELK53623L
RIGHT SIDE	YECO-YELK53624L

## FEATURES

- Complete structure manufactured from stainless steel
- Sturdy U-rail, wire shelves
- Fitted with interior LED lighting
- Automatic defrost function
- Fitted with 4 device leveling legs
- Fitted with lockable, reversible, self-closing doors
- The adjustable support rails can also be used for GN pans
- Ventilated cooling
- Digital Dixell / Carel thermostat



## DOUBLE DOOR FRIDGE

### SPECIFICATIONS

MODEL	PolarCab MBF8117
ELECTRICITY	0.35kW, 230V, Single Phase
DIMENSIONS	1315 x 805 x 2065mm high
WEIGHT	171kg
INTERNAL DIMENSIONS	1194 x 685 x 1550mm high
CAPACITY	1240Lt
RUNNER SPACING	100mm
GRIDS SUPPLIED	(6x) 530 x 630mm
TEMPERATURE RANGE	2 ~ 8°C
REFRIGERANT GAS	R600a

ORDER CODE **PCY/MBF8117**



## SINGLE DOOR FRIDGE

### SPECIFICATIONS

MODEL	PolarCab MBF8116
ELECTRICITY	0.22kW, 230V, Single Phase
DIMENSIONS	730 x 805 x 2065mm high
WEIGHT	107kg
INTERNAL DIMENSIONS	610 x 685 x 1550mm high
CAPACITY	670Lt
RUNNER SPACING	100mm
GRIDS SUPPLIED	(3x) 530 x 630mm
TEMPERATURE RANGE	2 ~ 8°C
REFRIGERANT GAS	R600a

ORDER CODE **PCY/MBF8116**



## DOUBLE DOOR FREEZER ❄️

### SPECIFICATIONS

MODEL	PolarCab MBF8114
ELECTRICITY	0.98kW, 230V, Single Phase
DIMENSIONS	1315 x 805 x 2065mm high
WEIGHT	177kg
INTERNAL DIMENSIONS	1194 x 685 x 1550mm high
CAPACITY	1240Lt
RUNNER SPACING	100mm
GRIDS SUPPLIED	(6x) 530 x 630mm
TEMPERATURE RANGE	-22 ~ -17°C
REFRIGERANT GAS	R290

ORDER CODE **PCY/MBF8114**



## SINGLE DOOR FREEZER ❄️

### SPECIFICATIONS

MODEL	PolarCab MBF8113
ELECTRICITY	0.6kW, 230V, Single Phase
DIMENSIONS	730 x 805 x 2065mm high
WEIGHT	115kg
INTERNAL DIMENSIONS	610 x 685 x 1550mm high
CAPACITY	670Lt
RUNNER SPACING	100mm
GRIDS SUPPLIED	(3x) 530 x 630mm
TEMPERATURE RANGE	-22 ~ -17°C
REFRIGERANT GAS	R290

ORDER CODE **PCY/MBF8113**



## OPTIONAL EXTRAS

### GRIDS

2/1 GN GRIDS	530 x 630mm
ORDER CODE	<b>OGS0021</b>

### SHELF RUNNERS

LEFT SIDE	<b>XPCY-80037407</b>
RIGHT SIDE	<b>XPCY-80037408</b>



CR 500



CRF 400 3D



CRF 400

**SINGLE DOOR FRIDGE**

**SPECIFICATIONS**

MODEL	Crystal CR 500
ELECTRICITY	0.36kW, 230V, Single Phase
DIMENSIONS	667 x 620 x 2018mm high
WEIGHT	102kg
INTERNAL DIMENSIONS	587 x 510 x 1593mm high
GROSS VOLUME	477Lt
GRIDS SUPPLIED	5
TEMPERATURE RANGE	2 ~ 7°C
REFRIGERANT GAS	R290

**ORDER CODE**                      **CRYGR-CR500**



**FEATURES**

- Body manufactured from non-toxic, pre-painted sheet steel
- Fitted with self-closing glass doors
- Internal LED lighting
- Fitted with a digital controller
- CR500 - EBD electronic evaporator fan motor
- Hi efficiency compressor
- Two regulators
- Air cooled condenser
- Drainage outlet
- CR500 - Auto-defrost function
- CR500 - (5x) adjustable reinforced shelves
- CRF400 - (6x) evaporation shelves + floor shelf
- Fitted with (4x) castors

**SINGLE DOOR FREEZER ❄️**

**SPECIFICATIONS**

MODEL	Crystal CRF 400
ELECTRICITY	0.82kW, 230V, Single Phase
DIMENSIONS	667 x 620 x 2018mm high
WEIGHT	108kg
INTERNAL DIMENSIONS	547 x 490 x 1553mm high
GROSS VOLUME	417Lt
RUNNER SPACING	170mm
GRIDS SUPPLIED	6
TEMPERATURE RANGE	-25 ~ -18°C
REFRIGERANT GAS	R290

**ORDER CODE**                      **CRYGR-CRF400**



**SINGLE DOOR FREEZER 180° VIEW ❄️**

**SPECIFICATIONS**

MODEL	Crystal CRF 400 3D
ELECTRICITY	0.82kW, 230V, Single Phase
DIMENSIONS	667 x 620 x 2018mm high
WEIGHT	118kg
INTERNAL DIMENSIONS	547 x 490 x 1553mm high
GROSS VOLUME	417Lt
RUNNER SPACING	170mm
GRIDS SUPPLIED	6
TEMPERATURE RANGE	-25 ~ -18°C
REFRIGERANT GAS	R290

**ORDER CODE**

**CRYGR-CR400-3D**



## HORIZONTAL DISPLAY FREEZERS



### FEATURES

- Manufactured from non-toxic, pre-painted sheet steel
- High efficiency compressor
- Air cooled condenser
- Mechanical thermostat
- Temperature display
- Sliding glass access panels
- Lock
- Drainage outlet
- Fitted with (4x) castors

### SPECIFICATIONS

MODEL	Crystal EKTOR 36 SGL
ELECTRICITY	0.2kW, 230V, Single Phase
DIMENSIONS	1184 x 644 x 895mm high
WEIGHT	58kg
INTERNAL DIMENSIONS	1060 x 520 x 737mm high
GROSS VOLUME	356Lt
TEMPERATURE RANGE	-26 ~ -18°C
REFRIGERANT GAS	R290

ORDER CODE

CRYGR-EKTO36SGL

## DISPLAY FREEZER / CHILLER TABLE MODEL



### FEATURES

- High grade stainless steel construction interior and exterior
- Self closing / stay open glass door
- Magnetic door gaskets
- Easy to clean black plastic door handle
- Fitted with a standard safety door lock
- Forced air system
- Heavy duty Embraco compressor
- Polyurethane foam insulation
- LED lighting installed
- Splash proof cover to control panel

### SPECIFICATIONS

MODEL	PolarCab MBC24FG
ELECTRICITY	0.53kW, 230V, Single Phase
EXTERIOR DIMENSIONS	605 x 635 x 825mm high
INTERIOR DIMENSIONS	495 x 517 x 561mm high
SHELVES SUPPLIED	(2x) 380 x 475mm
WEIGHT	59kg
TEMPERATURE RANGE	-20 ~ -17°C
REFRIGERANT GAS	R290

ORDER CODE

PCY/MBC24MG





## FEATURES

- AISI 304 stainless steel construction
- Inside fan support can be opened for easy cleaning
- Reversible, self-closing door
- Fitted with a built-in food probe for accurate temperature monitoring
- Controller with electronic time or probe programming
- Compatible with GN and 600 x 400mm baking trays
- Fitted with 4 devise levelling legs

## 15 PAN

### SPECIFICATIONS

**MODEL** MEC Cold ART151164  
**ELECTRICITY** 4.43kW, 380V, 3 Phase + N  
**DIMENSIONS** 820 x 860 x 1820mm high  
**WEIGHT** 160kg  
**CAPACITY** (15x) 1/1 GN trays  
 (15x) 600 x 400 mm trays  
**BLAST CHILL PERFORMANCE** 60kg, 70°C to 3°C in 90min  
**SHOCK FREEZE PERFORMANCE** 40kg, 70°C to -18°C in 90min  
**REFRIGERANT GAS** R404a

**ORDER CODE**

**BCM1511**



## 10 PAN

### SPECIFICATIONS

**MODEL** MEC Cold ART101164  
**ELECTRICITY** 3.35kW, 380V, 3 Phase + N  
**DIMENSIONS** 820 x 860 x 1470mm high  
**WEIGHT** 150kg  
**CAPACITY** (10x) 1/1 GN trays  
 (10x) 600 x 400 mm trays  
**BLAST CHILL PERFORMANCE** 40kg, 70°C to 3°C in 90min  
**SHOCK FREEZE PERFORMANCE** 25kg, 70°C to -18°C in 90min  
**REFRIGERANT GAS** R404a

**ORDER CODE**

**BCM1011**



## 5 PAN

### SPECIFICATIONS

**MODEL** MEC Cold ART51164  
**ELECTRICITY** 1.3kW, 230V, Single Phase  
**DIMENSIONS** 820 x 860 x 850mm high  
**WEIGHT** 90kg  
**CAPACITY** (5x) 1/1 GN trays  
 (5x) 600 x 400mm trays  
**BLAST CHILL PERFORMANCE** 20kg, 70°C to 3°C in 90min  
**SHOCK FREEZE PERFORMANCE** 13kg, 70°C to -18°C in 90min  
**REFRIGERANT GAS** R404a

**ORDER CODE**

**BCM0511**



## FEATURES

- Black units - Outer cabinet manufactured from coated mild steel
- Stainless steel units - Outer cabinet manufactured stainless steel
- High pressure injected 40mm cyclopentane insulation
- Cabinet interior manufactured from compressed aluminium
- 14W square fan assisted condenser
- Automatic defrost function
- Doors are fitted with tempered glass
- Fitted with adjustable feet for easy leveling
- Fitted with a digital temperature control and display
- Smooth action sliding doors / hinged doors
- Standard with internal LED lights and locks



## 3 DOOR

### SPECIFICATIONS

**MODEL** PolarCab LG320  
**ELECTRICITY** 0.67kW, 220V, Single Phase  
**EXTERNAL DIMENSIONS** 1350 x 520 x 850mm high  
**WEIGHT** 80kg  
**INTERNAL DIMENSIONS** 1260 x 385 x 700mm high  
**GROSS VOLUME** 320Lt  
**TEMPERATURE RANGE** 2 ~ 10°C  
**REFRIGERANT GAS** R600a  
**SHELVES SUPPLIED** (6x) 400 x 345mm

**SLIDING DOORS - BLACK** BBP0003  
**HINGED DOORS - BLACK** BBP1003  
**HINGED DOORS - S/STEEL** BBP3003



## 2 DOOR

### SPECIFICATIONS

**MODEL** PolarCab LG198  
**ELECTRICITY** 0.23kW, 220V, Single Phase  
**EXTERNAL DIMENSIONS** 900 x 520 x 850mm high  
**WEIGHT** 62kg  
**INTERNAL DIMENSIONS** 820 x 385 x 700mm high  
**GROSS VOLUME** 198Lt  
**TEMPERATURE RANGE** 2 ~ 10°C  
**REFRIGERANT GAS** R600a  
**SHELVES SUPPLIED** (4x) 400 x 345mm

**SLIDING DOORS - BLACK** BBP0002  
**HINGED DOORS - BLACK** BBP1002  
**HINGED DOORS - S/STEEL** BBP3002



## SINGLE DOOR

### SPECIFICATIONS

**MODEL** PolarCab LG128  
**ELECTRICITY** 0.18kW, 220V, Single Phase  
**EXTERNAL DIMENSIONS** 600 x 520 x 850mm high  
**WEIGHT** 46kg  
**INTERNAL DIMENSIONS** 520 x 385 x 700mm high  
**GROSS VOLUME** 128Lt  
**TEMPERATURE RANGE** 2 ~ 10°C  
**REFRIGERANT GAS** R600a  
**SHELVES SUPPLIED** (2x) 500 x 345mm

**HINGED DOOR - BLACK** BBP1001  
**HINGED DOOR - S/STEEL** BBP3001



**DIGITAL TEMPERATURE CONTROL AND DISPLAY**

# SALADETTE

## PREP / ASSEMBLY WORKTOP FRIDGE



SHOWN WITH OPTIONAL PIZZA  
INGREDIENT FRIDGE

### FEATURES

- Heavy duty construction, exterior and interior of high grade 304 stainless steel and galvanised steel back
- Fitted with granite top
- Automatic defrost
- Self closing doors
- Efficient refrigeration system
- Fitted with digital Dixell / Carel thermostat
- Supplied with GN tray slides in all doors
- Bottom mounted motor suitable for use in high temperature areas
- Fitted with (4x) adjustable legs

### SPECIFICATIONS

MODEL	PolarCab ELS3852
ELECTRICITY	0.22kW, 230V, Single Phase
DIMENSIONS	1365 x 700 x 1030mm high
WEIGHT	190kg
NUMBER OF DOORS	3
RUNNER SPACING	55mm
SHELVES SUPPLIED	(3x) GN 1/1 grids
CAPACITY	380Lt
TEMPERATURE RANGE	2 ~ 8°C
REFRIGERANT GAS	R134a

ORDER CODE

PCY/ELS3852



## PIZZA INGREDIENT FRIDGE



### 6 DIVISION 1/4 GN

#### SPECIFICATIONS

MODEL	PolarCab ESL3861
ELECTRICITY	0.3kW, 230V, Single Phase
DIMENSIONS	1400 x 335 x 435mm high
WEIGHT	41kg
CAPACITY	(6x) 1/4 GN pans (3x) 1/2 GN pans
TEMP RANGE	2 ~ 8°C
REFRIGERANT GAS	R134a

ORDER CODE

PCY/ESL3861



### FEATURES

- Compact design to minimize footprint
- Glass panels are easy to remove for cleaning
- Low maintenance auto defrost function
- Can accommodate 1/4 and 1/2 GN pans
- Fitted with digital temperature controller
- Insert pans not included





# SALADETTE

## GRANITE TOP WITH SNEEZE GUARD



### FEATURES

- Exterior and interior manufactured from 304 Stainless Steel and Galvanised steel back
- Fitted with granite top
- Fitted with glass sneeze guard
- Automatic defrost
- Self closing doors
- Efficient refrigeration system
- Fitted with digital Dixell / Carel thermostat
- Supplied with GN tray slides in all doors
- Bottom mounted motor suitable for use in high temperature areas
- Insert pans not included
- Fitted with (4x) adjustable legs



### SPECIFICATIONS

MODEL	PolarCab ELS3864
ELECTRICITY	0.31kW, 230V, Single Phase
DIMENSIONS	1365 x 700 x 1100mm high
WEIGHT	170kg
NUMBER OF DOORS	3
RUNNER SPACING	55mm
SHELVES SUPPLIED	(3x) GN 1/1 grids
CAPACITY	380Lt
DISPLAY CAPACITY	(7x) 1/3 GN pans
TEMPERATURE RANGE	2 ~ 8°C
REFRIGERANT GAS	R134a

ORDER CODE

PCY/ELS3864



## SALADETTE

### PIZZA TOP WITH HINGED LID



#### FEATURES

- Exterior and interior manufactured from 304 Stainless Steel and Galvanised steel back
- Bottom mounted motor suitable for use in high temperature areas
- Automatic defrost
- Efficient refrigeration system
- Supplied with GN tray slides in all doors
- Fitted with (4x) adjustable legs
- Self closing doors
- Fitted with digital Dixell / Carel thermostat
- Insert pans not included



#### SPECIFICATIONS

MODEL	PolarCab EL3853
ELECTRICITY	0.31kW, 230V, Single Phase
DIMENSIONS	1365 x 700 x 1040mm high
WEIGHT	105kg
NUMBER OF DOORS	3
RUNNER SPACING	55mm
SHELVES SUPPLIED	(3x) GN 1/1 grids
CAPACITY	380Lt
TEMPERATURE RANGE	2 ~ 8°C
REFRIGERANT GAS	R134a

#### ORDER CODE

PCY/ELS3853



## SALADETTE

### CUTTING BOARD WITH HINGED LID

#### FEATURES

- Exterior and interior manufactured from 304 Stainless Steel and Galvanised steel back
- Bottom mounted motor suitable for use in high temperature areas
- Automatic defrost
- Efficient refrigeration system
- Supplied with GN tray slides in all doors
- Fitted with (4x) adjustable legs
- Self closing doors
- Fitted with digital Dixell / Carel thermostat
- Insert pans not included



#### SPECIFICATIONS

MODEL	PolarCab EL3850
ELECTRICITY	0.31kW, 230V, Single Phase
DIMENSIONS	1365 x 700 x 890mm high
WEIGHT	87kg
NUMBER OF DOORS	3
RUNNER SPACING	55mm
SHELVES SUPPLIED	(3x) GN 1/1 grids
CAPACITY	380Lt
TEMPERATURE RANGE	2 ~ 8°C
REFRIGERANT GAS	R134a

#### ORDER CODE

PCY/ELS3850



**FEATURES**

- Stainless steel exterior and interior
- Dixell digital controller
- Recessed door handles
- Magnetic drawer gaskets
- Pre-installed casters
- One-Piece heavy duty reinforced stainless steel top
- Heavy Duty Embraco Controller
- Heavy Duty stainless steel drawer slides and rollers
- Gravity fed self closing drawers
- Stainless steel pans included



**1800mm**

**SPECIFICATIONS**

MODEL	CookRite MGF8453GR
ELECTRICITY	0.3kW, 230V, Single Phase
DIMENSIONS	1840 x 814 x 675mm high
WEIGHT	136kg
NUMBER OF DRAWERS	4
PANS PER DRAWER	(2x) 1/1GN
TEMPERATURE RANGE	2 ~ 5°C
REFRIGERANT GAS	R290

ORDER CODE

CR/MGF8453GR



**1200mm**

**SPECIFICATIONS**

MODEL	CookRite MGF8450GR
ELECTRICITY	0.3kW, 230V, Single Phase
DIMENSIONS	1230 x 814 x 675mm high
WEIGHT	117kg
NUMBER OF DRAWERS	2
PANS PER DRAWER	(2x) 1/1GN
TEMPERATURE RANGE	2 ~ 5°C
REFRIGERANT GAS	R290

ORDER CODE

CR/MGF8450GR

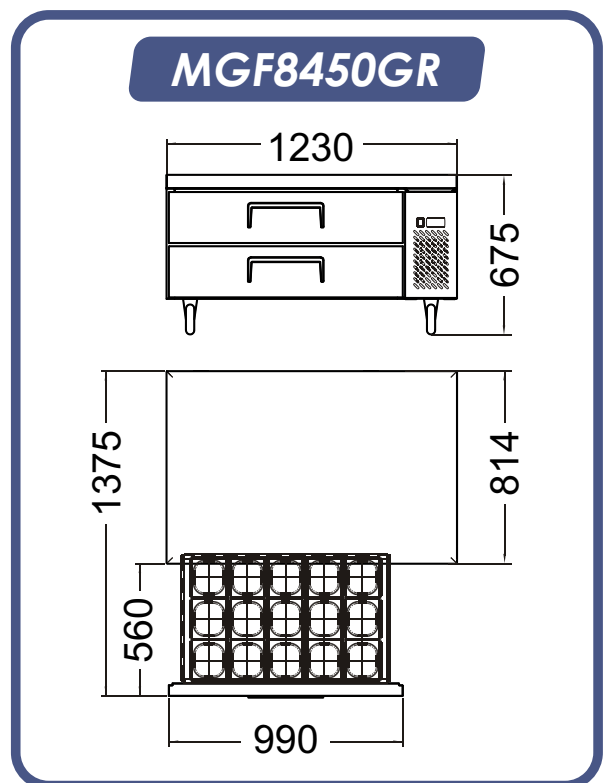
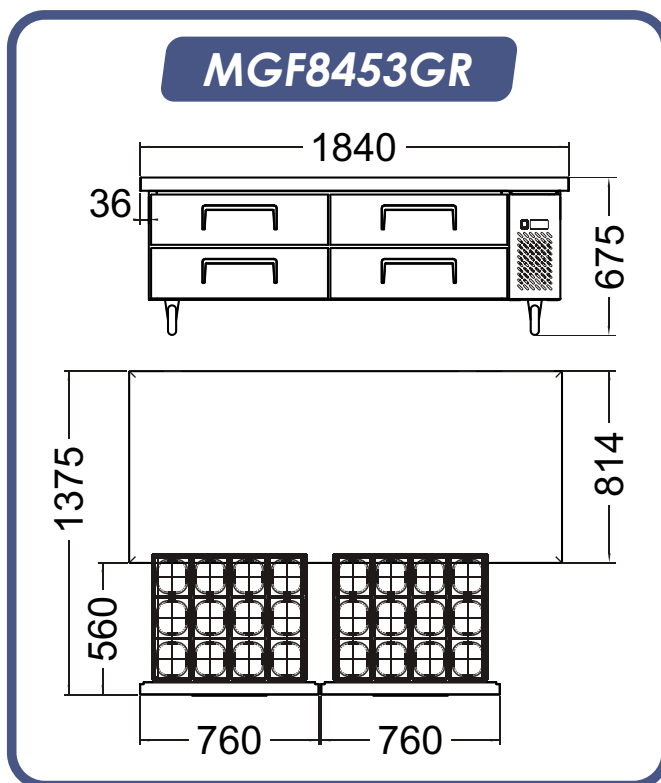



## FEATURES

- Body manufactured from AISI304 stainless steel
- Unit requires installation, water connection and a waste drainage point
- Electromechanical unit - no PC boards
- Ice production calculated at ambient temperature 21°C and water temperature 15°C

## INSTALLATION CONDITIONS

- Ambient temperature: Min +10°C / Max +38°C
- Water temperature: Min +3°C / Max +28°C
- Voltage: +/-10%
- Water pressure: Min 1 bar (14psi) / Max 6 bar (84psi)

## GOURMET CUBES - 300kg



### SPECIFICATIONS

MODEL	Brice ECPM300A
ELECTRICITY	2.6kW, 220V, Single Phase
DIMENSIONS	1250 x 580 x 848mm high
WEIGHT	152kg
PRODUCTION /24H	300kg
CUBE	Gourmet Bell shape - 18gr
REFRIGERANT GAS	R452a
COMPATIBLE BIN	IMB/BIN350

**ORDER CODE**                      **IMB/ECPM300A**

## GOURMET CUBES - 155kg



### SPECIFICATIONS

MODEL	Brice ECPM150A
ELECTRICITY	1.4kW, 220V, Single Phase
DIMENSIONS	862 x 555 x 720mm high
WEIGHT	118kg
PRODUCTION /24H	155kg
CUBE	Gourmet Bell shape - 18gr
REFRIGERANT GAS	R452a
COMPATIBLE BIN	IMB/BIN240 • IMB/BIN350

**ORDER CODE**                      **IMB/ECPM150A**

## FLAT CUBE - 400kg



### SPECIFICATIONS

MODEL	Brice EFM500A
ELECTRICITY	3kW, 220V, Single Phase
DIMENSIONS	770 x 550 x 805mm high
WEIGHT	113kg
PRODUCTION /24H	400kg
CUBE	Flat shape - 7gr
REFRIGERANT GAS	R452a
COMPATIBLE BIN	IMB/BIN350

**ORDER CODE**                      **IMB/EFM500A**

## FLAT CUBE - 200kg



### SPECIFICATIONS

MODEL	Brice EFM200A
ELECTRICITY	1.6kW, 220V, Single Phase
DIMENSIONS	770 x 555 x 805mm high
WEIGHT	90kg
PRODUCTION /24H	200kg
CUBE	Flat shape - 7gr
REFRIGERANT GAS	R452a
COMPATIBLE BIN	IMB/BIN240 • IMB/BIN350

**ORDER CODE**                      **IMB/EFM200A**

## ICE FLAKER - 280kg



### SPECIFICATIONS

MODEL	Brice EMS280A
ELECTRICITY	1.05kW, 220V, Single Phase
DIMENSIONS	560 x 670 x 695mm high
WEIGHT	83kg
PRODUCTION /24H	280kg
CUBE	Flakes
REFRIGERANT GAS	R452a
COMPATIBLE BIN	IMB/BIN350

**ORDER CODE**                      **IMB/EMS280A**

## ICE FLAKER - 160kg



### SPECIFICATIONS

MODEL	Brice EMS160A
ELECTRICITY	1.05kW, 220V, Single Phase
DIMENSIONS	560 x 570 x 600mm high
WEIGHT	63kg
PRODUCTION /24H	160kg
CUBE	Flakes
REFRIGERANT GAS	R452a
COMPATIBLE BIN	IMB/BIN240 • IMB/BIN350

**ORDER CODE**                      **IMB/EMS160A**

# MODULAR ICE MACHINES, BINS



## FEATURES

- Manufactured from Stainless Steel
- Wide opening Stainless Steel lid for easy access to the ice
- Fully insulated
- Available in 350Lt and 240Lt units
- Fitted with adjustable feet

## 350 LITRE SPECIFICATIONS

MODEL BIN350  
 DIMENSIONS 1250 x 750 x 1000mm high  
 WEIGHT 75kg  
 CAPACITY 350Lt  
 COMPATIBLE WITH ECPM150A • ECPM300A  
 ECPM200A • EFM500A  
 ESM160A • ESM280A

ORDER CODE **IMB/BIN350**



## 240 LITRE SPECIFICATIONS

MODEL BIN240  
 DIMENSIONS 1000 x 750 x 1000mm high  
 WEIGHT 60kg  
 CAPACITY 240Lt  
 COMPATIBLE WITH ECPM150A • EFM200A  
 ESM160A

ORDER CODE **IMB/BIN240**



**ICE MACHINE  
SHOWN WITH ICE BIN**





**GOURMET  
CUBE**

## FEATURES

- Body manufactured from AISI304 stainless steel
- Unit requires installation, water connection and a waste drainage point
- Electromechanical unit - no PC boards
- Ice production calculated at ambient temperature 21°C and water temperature 15°C

## INSTALLATION CONDITIONS

- Ambient temperature: Min +10°C / Max +38°C
- Water temperature: Min +3°C / Max +28°C
- Voltage: +/-10%
- Water pressure: Min 1 bar (14psi) / Max 6 bar (84psi)

## 155kg

### SPECIFICATIONS

MODEL	Brice ECP155A
ELECTRICITY	1.4kW, 220V, Single Phase
DIMENSIONS	840 x 740 x 1075mm high
WEIGHT	118kg
PRODUCTION /24H	155kg
STORAGE CAPACITY	65kg
CUBE	Gourmet Bell shape - 18gr
REFRIGERANT GAS	R452a

ORDER CODE

IMB/ECP155A



## 100kg

### SPECIFICATIONS

MODEL	Brice ECP100A
ELECTRICITY	0.87kW, 220V, Single Phase
DIMENSIONS	735 x 603 x 1010mm high
WEIGHT	74kg
PRODUCTION /24H	100kg
STORAGE CAPACITY	60kg
CUBE	Gourmet Bell shape - 18gr
REFRIGERANT GAS	R452a

ORDER CODE

IMB/ECP100A



## 80kg

### SPECIFICATIONS

MODEL	Brice ECP80A
ELECTRICITY	0.89kW, 220V, Single Phase
DIMENSIONS	735 x 603 x 910mm high
WEIGHT	71kg
PRODUCTION /24H	88kg
STORAGE CAPACITY	40kg
CUBE	Gourmet Bell shape - 18gr
REFRIGERANT GAS	R452a

ORDER CODE

IMB/ECP80A



## 46kg

### SPECIFICATIONS

MODEL	Brice ECP46A
ELECTRICITY	0.45kW, 220V, Single Phase
DIMENSIONS	497 x 592 x 687mm high
WEIGHT	43kg
PRODUCTION /24H	46kg
STORAGE CAPACITY	16kg
CUBE	Gourmet Bell shape - 18gr
REFRIGERANT GAS	R452a

ORDER CODE

IMB/ECP46A



## 28kg

### SPECIFICATIONS

MODEL	Brice ECF28A
ELECTRICITY	0.27kW, 220V, Single Phase
DIMENSIONS	387 x 470 x 687mm high
WEIGHT	33kg
PRODUCTION /24H	25kg
STORAGE CAPACITY	9kg
CUBE	Gourmet Bell shape - 18gr
REFRIGERANT GAS	R452a

ORDER CODE

IMB/ECF28A

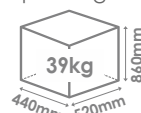

## 18kg

### SPECIFICATIONS

MODEL	Brice ECP18A
ELECTRICITY	0.32kW, 220V, Single Phase
DIMENSIONS	355 x 404 x 590mm high
WEIGHT	28kg
PRODUCTION /24H	22kg
STORAGE CAPACITY	4kg
CUBE	Gourmet Bell shape - 13gr
REFRIGERANT GAS	R452a

ORDER CODE

IMB/ECP18A





## FEATURES

- Durable body with s/s cabinet
- Space saving design
- Ideal for bar and undercounter application
- Removable filter for easy cleaning - Protects against condenser blockage
- Supplied with in-line water filter
- Supplied with water inlet pipe, ice scoop and water drainage pipe
- LCD control panel

## INSTALLATION CONDITIONS

- Ambient temperature: Min +10°C / Max +38°C
- Water temperature: Min +3°C / Max +28°C
- Voltage: +/-10%
- Water pressure: Min 1 bar (14psi) / Max 6 bar (84psi)

## 60kg

### SPECIFICATIONS

MODEL	PolarCab LB120S-C
ELECTRICITY	0.42kW, 220V, Single Phase
DIMENSIONS	510 x 600 x 840mm high
WEIGHT	45kg
PRODUCTION /24H	60kg
STORAGE CAPACITY	27kg
CUBE	Square Cube shape - 8gr
REFRIGERANT GAS	R404a

ORDER CODE                      IMP/LB120S-C



## 40kg

### SPECIFICATIONS

MODEL	PolarCab LB80S-C
ELECTRICITY	0.32kW, 220V, Single Phase
DIMENSIONS	510 x 450 x 840mm high
WEIGHT	35kg
PRODUCTION /24H	40kg
STORAGE CAPACITY	20kg
CUBE	Square Cube shape - 8gr
REFRIGERANT GAS	R134a

ORDER CODE                      IMP/LB80S-C



## 25kg

### SPECIFICATIONS

MODEL	PolarCab LB55S-C
ELECTRICITY	0.26kW, 220V, Single Phase
DIMENSIONS	510 x 450 x 840mm high
WEIGHT	35kg
PRODUCTION /24H	25kg
STORAGE CAPACITY	20kg
CUBE	Square Cube shape - 8gr
REFRIGERANT GAS	R134a

ORDER CODE                      IMP/LB55S-C



# SQUARE CUBE



# GELATO MACHINES COUNTER TOP



## FEATURES

- Body manufactured from stainless steel
- Compact design uses less workspace
- Transparent polycarbonate feeder hopper located in the front of the machine for easy and accurate operation
- Large stainless steel freezing cylinder increases output and "fluffiness" of the ice cream
- Retractable, rotating mixer blade inside the cylinder further improves the smoothness of the ice cream
- Fitted with a powerful, energy saving compressor
- Fitted with a digital, waterproof control panel
- Fitted with (4x) non-slip feet

## SPECIFICATIONS

MODEL	Goshen BQ12T
ELECTRICITY	1kW, 220V, Single Phase
DIMENSIONS	500 x 705 x 800mm high
WEIGHT	110kg
HOPPER VOLUME	5.1Lt
REFRIGERANT GAS	R404a
HOURLY OUTPUT	10 ~ 14Lt/hour

## ORDER CODE

ICM/BQ12T



## OPTIONAL EXTRAS

ICE CREAM INSERT - 360 x 165 x 120mm deep  
ORDER CODE **GNI8120**

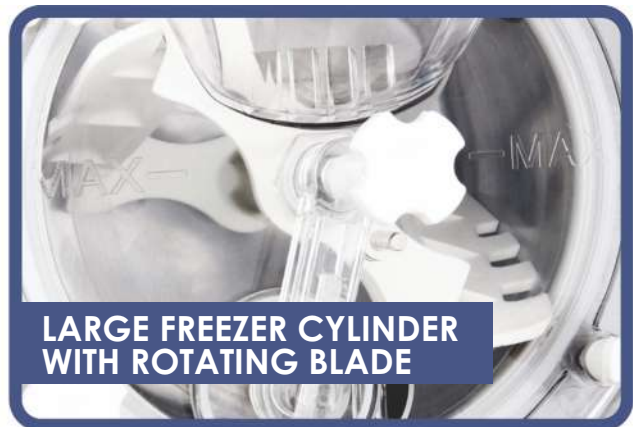



# SOFT SERVE MACHINES COUNTER TOP



## FEATURES

- Exquisite modern design. Small and portable
- Silent operation
- Fitted with a stainless steel refrigerated hopper
- Mixer installed inside hopper makes for smoother ice cream
- Fitted with a stainless steel beater
- Built-in air pump
- Fitted with a 7inch, touch screen control panel
- One-touch thaw function
- Fitted with (4x) non-slip feet



## FEATURES

- Exquisite modern design. Small and portable
- Silent operation
- Fitted with a stainless steel hopper
- Fitted with a food grade plastic beater
- Built-in air pump
- Fitted with a 5inch, waterproof, touch control panel
- Built-in thaw function
- Fitted with (4x) non-slip feet
- Available in 3 exciting candy colours



## COOL & COMPACT SPECIFICATIONS

MODEL	Goshen ST16RELW
ELECTRICITY	1.25kW, 220V, Single Phase
DIMENSIONS	210 x 554 x 740mm high
WEIGHT	45kg
HOPPER VOLUME	6Lt
REFRIGERANT GAS	R290
HOURLY OUTPUT	16 ~ 18Lt/hour
REALISTIC OUTPUT	12Lt (100 x 120g servings)

ORDER CODE **SSM/ST16RELW-W**

## COMPACT SPECIFICATIONS

MODEL	Goshen ST16E
ELECTRICITY	1.15kW, 220V, Single Phase
DIMENSIONS	210 x 554 x 740mm high
WEIGHT	43kg
HOPPER VOLUME	6Lt
REFRIGERANT GAS	R290
HOURLY OUTPUT	16 ~ 18Lt/hour
REALISTIC OUTPUT	12Lt (100 x 120g servings)

ORDER CODE **SSM/ST16E-W**  WHITE  
**SSM/ST16E-P**  PINK  
**SSM/ST16E-Y**  YELLOW



# SOFT SERVE MACHINES WITH REFRIGERATED HOPPER



## FEATURES

- Compact design - can be installed in small areas
- Unique mixing shaft manufactured with stainless steel axes with non-toxic corkscrew plastic scrapers
- Fitted with 2 stainless steel refrigerated hoppers with clear plastic lids for easy viewing
- Quick recovery time
- Low noise and vibrations
- Gravity feed machine
- Easy to disassemble and clean
- Fitted with removable plastic drip tray
- IT Push panel (one touch switch) controller with indicator light for easy operation



## FLOOR STANDING

### SPECIFICATIONS

MODEL	PolarCab SQL-922
ELECTRICITY	2kW, 230V, Single Phase
DIMENSIONS	550 x 700 x 1330mm high
WEIGHT	140kg
REFRIGERANT GAS	R22
HOPPER CAPACITY	(2x) 5.8Lt
OUTPUT PER HOUR	180 cones

ORDER CODE

SSM1002



## TABLE MODEL

### SPECIFICATIONS

MODEL	PolarCab SQL-922C
ELECTRICITY	2kW, 230V, Single Phase
DIMENSIONS	550 x 700 x 1080mm high
WEIGHT	115kg
REFRIGERANT GAS	R22
HOPPER CAPACITY	(2x) 5.8Lt
OUTPUT PER HOUR	180 cones

ORDER CODE

SSM1001



# SOFT SERVE MACHINES WITH DOUBLE BARREL

**SmartChef**



## FEATURES

- Easy to operate touch control panel
- Fitted with (2x) stainless steel hoppers
- Quick recovery time
- Low noise and vibration
- Gravity feed machine
- Easy to disassemble and clean
- Fitted with removable plastic drip tray for easy cleaning
- Fitted with (4x) castors

## FLOOR STANDING

### SPECIFICATIONS

MODEL	SmartChef HIM-02
ELECTRICITY	1.7kW, 230V, Single Phase
DIMENSIONS	700 x 900 x 1435mm high
WEIGHT	135kg
REFRIGERANT GAS	R22/R404A
HOPPER CAPACITY	(2x) 6.5L†
OUTPUT PER HOUR	90 cones

ORDER CODE

SSM-HIM-02



# ICE CREAM SCOOP FREEZERS TABLE MODEL

*Galileo*

## FEATURES

- Stainless steel exterior and interior finish with tempered glass
- Fan assisted cooling
- Digital controller and temperature display
- Removable sliding door for easy cleaning
- Fully automatic
- Fan assisted condenser
- Interior LED light with switch
- Removable door gasket



## 5 DIVISION SPECIFICATIONS

MODEL Galileo TSF-120  
 ELECTRICITY 0.75kW, 230V, Single Phase  
 DIMENSIONS 1200 x 550 x 790mm high  
 WEIGHT 140kg  
 CAPACITY (5x) 1/3 GN inserts - 100mm  
 TEMPERATURE RANGE -18 ~ -12°C  
 REFRIGERANT GAS R404a

ORDER CODE IFG/TSF-120



## 3 DIVISION SPECIFICATIONS

MODEL Galileo TSF-90  
 ELECTRICITY 0.65kW, 230V, Single Phase  
 DIMENSIONS 900 x 550 x 790mm high  
 WEIGHT 120kg  
 CAPACITY (3x) 1/3 GN inserts - 100mm  
 TEMPERATURE RANGE -18 ~ -12°C  
 REFRIGERANT GAS R404a

ORDER CODE IFG/TSF-90



# ICE CREAM SCOOP FREEZERS FLOOR STANDING



## FEATURES

- Manufactured from non-toxic sheet steel
- High efficiency compressor
- Air cooled condenser
- Mechanical Thermostat
- Temperature display
- Stainless steel sockets for stainless steel or plastic ice cream inserts
- Storage space with a separate door
- Serving bench with a scoop washer system
- LED Illuminated canopy
- Fitted with (4x) castors
- Supplied without inserts

## SPECIFICATIONS

MODEL	Crystal ELEGANTE 36
ELECTRICITY	0.23kW, 230V, Single Phase
DIMENSIONS	1206 x 862 x 1263mm high
WEIGHT	90kg
INTERNAL DIMENSIONS	1060 x 560 x 688mm high
GROSS VOLUME	358Lt
BIN CAPACITY	(9x) 360 x 165mm S/steel bins (9x) 360 x 155mm Plastic bins
TEMPERATURE RANGE	-22 ~ -15°C
REFRIGERANT GAS	R290

## ORDER CODE

CRYGR-ELEGANT36



**SEPARATE STORAGE SPACE**

## OPTIONAL EXTRAS

ICE CREAM INSERT - 360 x 165 x 120mm deep  
ORDER CODE GNI8120





 **IGLOO**  
**OPEN COOLER MERCHANDISER**

## SECTION INDEX

<i>Display cabinets</i>	
• Heated .....	155, 157, 159
• Neutral .....	153, 157, 159
• Refrigerated .....	152, 154-156, 158
Floor standing display cabinets .....	152-154, 156-159
Heated Display cabinets .....	155, 157, 159
Ice cream scoop freezers .....	164
<i>Merchandisers</i>	
• Open cooler .....	161
• Open island .....	162-163
• Wall chillers .....	161
Neutral Display cabinets .....	153, 157, 159
Open cooler merchandisers .....	161
Open island merchandisers .....	162-163
Pie warmers .....	164
Pizza ingredient fridges .....	165
Refrigerated Display cabinets .....	152, 154-156, 158
Sneeze guards .....	160
Table model display cabinets .....	155, 164
Wall chillers .....	161

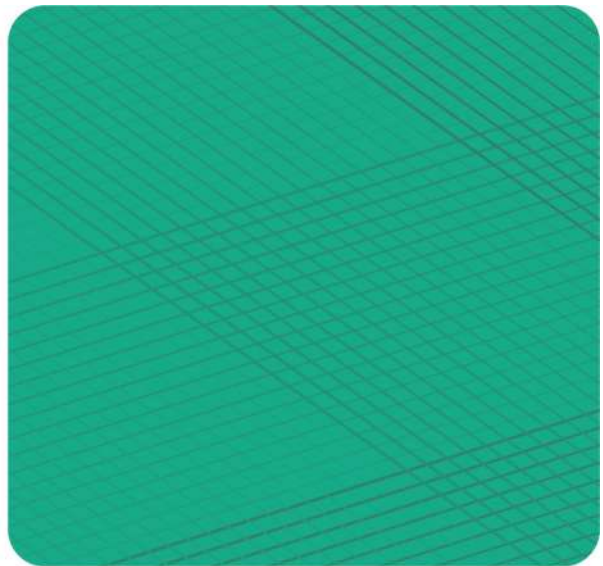



**FEATURES**

- Stainless steel decorative front panel
- Fitted with a SECOP compressor
- Electric heating front glass for de-fogging
- Fitted with removable, sliding glass doors
- Fitted with adjustable feet
- LED lighting under each shelf - Energy saving
- Fitted with a Dixell electronic controller
- Automatic defrost function
- Supplied with 3 adjustable stainless steel shelves

**1.5 METER**

**SPECIFICATIONS**

MODEL Galileo WDF157Z  
 ELECTRICITY 0.83kW, 220V, Single Phase  
 DIMENSIONS 1500 x 750 x 1350mm high  
 WEIGHT 298kg  
 DISPLAY SURFACE 2.55m<sup>2</sup>  
 SHELF DIM (3x) 1395 x 345mm  
 (1x) 1500 x 740mm  
 TEMP RANGE 2 ~ 8°C  
 REFRIGERANT GAS R290

**ORDER CODE**

**DCG/WDF157Z**



**1.2 METER**

**SPECIFICATIONS**

MODEL Galileo WDF127Z  
 ELECTRICITY 0.74kW, 220V, Single Phase  
 DIMENSIONS 1200 x 750 x 1350mm high  
 WEIGHT 273kg  
 DISPLAY SURFACE 2.02m<sup>2</sup>  
 SHELF DIMENSIONS (3x) 1095 x 345mm  
 (1x) 1200 x 740mm  
 TEMP RANGE 2 ~ 8°C  
 REFRIGERANT GAS R290

**ORDER CODE**

**DCG/WDF127Z**



**0.9 METER**

**SPECIFICATIONS**

MODEL Galileo WDF097Z  
 ELECTRICITY 0.53kW, 220V, Single Phase  
 DIMENSIONS 900 x 750 x 1350mm high  
 WEIGHT 231kg  
 DISPLAY SURFACE 1.48m<sup>2</sup>  
 SHELF DIMENSIONS (3x) 795 x 345mm  
 (1x) 900 x 740mm  
 TEMP RANGE 2 ~ 8°C  
 REFRIGERANT GAS R290

**ORDER CODE**

**DCG/WDF097Z**



**SLIDING BACK DOORS**



# NEUTRAL DISPLAY CABINETS

## HIGH CUBE

*Galileo*



### FEATURES

- Stainless steel decorative front panel
- Fitted with removable, sliding glass doors
- Fitted with adjustable feet
- LED lighting under each shelf - Energy saving
- Supplied with 3 adjustable stainless steel shelves

### 1.5 METER

#### SPECIFICATIONS

MODEL Galileo WDF157ZSA11  
 ELECTRICITY 0.2kW, 220V, Single Phase  
 DIMENSIONS 1500 x 750 x 1350mm high  
 WEIGHT 288kg  
 DISPLAY SURFACE 2.55m<sup>2</sup>  
 SHELF DIM (3x) 1395 x 345mm  
 (1x) 1500 x 740mm

ORDER CODE DCG/WDF157ZSA11



### 1.2 METER

#### SPECIFICATIONS

MODEL Galileo WDF127ZSA11  
 ELECTRICITY 0.2kW, 220V, Single Phase  
 DIMENSIONS 1200 x 750 x 1350mm high  
 WEIGHT 263kg  
 DISPLAY SURFACE 2.02m<sup>2</sup>  
 SHELF DIMENSIONS (3x) 1095 x 345mm  
 (1x) 1200 x 740mm

ORDER CODE DCG/WDF127ZSA11



### 0.9 METER

#### SPECIFICATIONS

MODEL Galileo WDF097ZSA11  
 ELECTRICITY 0.2kW, 220V, Single Phase  
 DIMENSIONS 900 x 750 x 1350mm high  
 WEIGHT 221kg  
 DISPLAY SURFACE 1.48m<sup>2</sup>  
 SHELF DIMENSIONS (3x) 795 x 345mm  
 (1x) 900 x 740mm

ORDER CODE DCG/WDF097ZSA11



ADJUSTABLE FEET

# REFRIGERATED DISPLAY CABINETS

## LOW CUBE

*Galileo*



### FEATURES

- Stainless steel decorative front panel
- Fitted with a SECOP compressor
- Electric heating front glass for de-fogging
- Fitted with removable, sliding glass doors
- Fitted with adjustable feet
- LED lighting under each shelf - Energy saving
- Fitted with a Dixell electronic controller
- Automatic defrost function
- Supplied with 2 adjustable stainless steel shelves

### 1.2 METER

#### SPECIFICATIONS

MODEL Galileo WDF127F  
 ELECTRICITY 0.7kW, 220V, Single Phase  
 DIMENSIONS 1200 x 750 x 1200mm high  
 WEIGHT 243kg  
 DISPLAY SURFACE 1.64m<sup>2</sup>  
 SHELF DIMENSIONS (2x) 1095 x 345mm  
 (1x) 1200 x 740mm  
 TEMP RANGE 2 ~ 8°C  
 REFRIGERANT GAS R290

ORDER CODE

DCG/WDF127F



### 0.9 METER

#### SPECIFICATIONS

MODEL Galileo WDF097F  
 ELECTRICITY 0.51kW, 220V, Single Phase  
 DIMENSIONS 900 x 750 x 1200mm high  
 WEIGHT 200kg  
 DISPLAY SURFACE 1.2m<sup>2</sup>  
 SHELF DIMENSIONS (2x) 795 x 345mm  
 (1x) 900 x 740mm  
 TEMP RANGE 2 ~ 8°C  
 REFRIGERANT GAS R290

ORDER CODE

DCG/WDF097F



## REFRIGERATED DISPLAY CABINETS COUNTER TOP

# Galileo



### FEATURES

- Stainless steel exterior & interior
- Removable water pan to add humidity
- Fitted with an electronic digital controller
- (2x) stainless steel shelves standard
- Maintains temperatures between 2°C ~ 8°C
- (2x) rear sliding glass doors
- LED interior lighting - Energy saving and durable
- Fitted with (4x) leveling feet

### 0.9 METER

#### SPECIFICATIONS

MODEL Galileo WTF160L  
ELECTRICITY 0.24kW, 220V, Single Phase  
DIMENSIONS 900 x 560 x 670mm high  
WEIGHT 75kg  
DISPLAY SURFACE 1.07m<sup>2</sup>  
SHELF DIMENSIONS (1x) 850 x 288mm  
(1x) 850 x 338mm  
(1x) 850 x 640mm

TEMP RANGE 2 ~ 8°C  
REFRIGERANT GAS R290

ORDER CODE

DCG/WTF160L



### 0.7 METER

#### SPECIFICATIONS

MODEL Galileo WTF120L  
ELECTRICITY 0.23kW, 220V, Single Phase  
DIMENSIONS 700 x 560 x 670mm high  
WEIGHT 65kg  
DISPLAY SURFACE 0.67m<sup>2</sup>  
SHELF DIMENSIONS (1x) 650 x 288mm  
(1x) 650 x 338mm  
(1x) 650 x 400mm

TEMP RANGE 2 ~ 8°C  
REFRIGERANT GAS R290

ORDER CODE

DCG/WTF120L



## HEATED DISPLAY CABINETS COUNTER TOP



### FEATURES

- Stainless steel exterior & interior
- Removable water pan to add humidity
- Fitted with an electronic digital controller
- (3x) stainless steel shelves standard
- Maintains temperatures between 30°C ~ 90°C
- (2x) rear sliding glass doors
- LED interior lighting - Energy saving and durable
- Fitted with (4x) leveling feet

### 0.9 METER

#### SPECIFICATIONS

MODEL Galileo WHF200L  
ELECTRICITY 1.65kW, 220V, Single Phase  
DIMENSIONS 900 x 570 x 678mm high  
WEIGHT 70kg  
DISPLAY SURFACE 0.86m<sup>2</sup>  
SHELF DIMENSIONS (3x) 850 x 338mm  
TEMP RANGE 30 ~ 90°C

ORDER CODE

DCG/WHF200L



### 0.7 METER

#### SPECIFICATIONS

MODEL Galileo WHF150L  
ELECTRICITY 1.25kW, 220V, Single Phase  
DIMENSIONS 700 x 570 x 678mm high  
WEIGHT 60kg  
DISPLAY SURFACE 0.66m<sup>2</sup>  
SHELF DIMENSIONS (3x) 650 x 338mm  
TEMP RANGE 30 ~ 90°C

ORDER CODE

DCG/WHF150L



## FEATURES

- Internal heated / cooling aggregate
- Front panel manufactured from stainless steel
- 2 Glass shelves with height and angle adjustable frames
- Internal top and each shelf illuminated with LED lights
- Electronic temperature controller with digital display
- External housing manufactured stainless steel
- Glass side panels
- Back sliding doors with combined glass
- Automatic defrost on refrigerated units
- Fitted with height adjustable feet



## REFRIGERATED DISPLAY CABINETS

### 1.3 METER

#### SPECIFICATIONS

MODEL Igloo Cube 1.3  
 ELECTRICITY 0.3kW, 220V, Single Phase  
 DIMENSIONS 1310 x 840 x 1250 mm high  
 WEIGHT 210kg  
 DISPLAY SURFACE 1.9m<sup>2</sup>  
 SHELF DIMENSIONS (1x) 1280 x 425mm  
 (1x) 1280 x 515mm  
 (1x) 1290 x 525mm  
 TEMP RANGE 5 ~ 15°C  
 REFRIGERANT GAS R134a

ORDER CODE

IGL8013



### 0.9 METER

#### SPECIFICATIONS

MODEL Igloo Cube 0.9  
 ELECTRICITY 0.3kW, 220V, Single Phase  
 DIMENSIONS 910 x 840 x 1250mm high  
 WEIGHT 170kg  
 DISPLAY SURFACE 1.3m<sup>2</sup>  
 SHELF DIMENSIONS (1x) 870 x 425mm  
 (1x) 870 x 515mm  
 (1x) 880 x 525mm  
 TEMP RANGE 5 ~ 15°C  
 REFRIGERANT GAS R134a

ORDER CODE

IGL8009



### 0.6 METER

#### SPECIFICATIONS

MODEL Igloo Cube 0.6  
 ELECTRICITY 0.3kW, 220V, Single Phase  
 DIMENSIONS 610 x 840 x 1250mm high  
 WEIGHT 120kg  
 DISPLAY SURFACE 0.87m<sup>2</sup>  
 SHELF DIMENSIONS (1x) 570 x 425mm  
 (1x) 570 x 515mm  
 (1x) 580 x 525mm  
 TEMP RANGE 5 ~ 15°C  
 REFRIGERANT GAS R134a

ORDER CODE

IGL8006



## HEATED DISPLAY CABINETS

### 1.3 METER SPECIFICATIONS

MODEL Igloo Cube 1.3  
 ELECTRICITY 3kW, 230V, Single Phase  
 DIMENSIONS 1310 x 840 x 1250 mm high  
 WEIGHT 220kg  
 DISPLAY SURFACE 1.9m<sup>2</sup>  
 SHELF DIMENSIONS (1x) 1280 x 425mm  
 (1x) 1280 x 515mm  
 (1x) 1290 x 525mm  
 TEMP RANGE 30 ~ 60°C

ORDER CODE IGL8113



### 0.9 METER SPECIFICATIONS

MODEL Igloo Cube 0.9  
 ELECTRICITY 3kW, 220V, Single Phase  
 DIMENSIONS 910 x 840 x 1250mm high  
 WEIGHT 170kg  
 DISPLAY SURFACE 1.3m<sup>2</sup>  
 SHELF DIMENSIONS (1x) 870 x 425mm  
 (1x) 870 x 515mm  
 (1x) 880 x 525mm  
 TEMP RANGE 30 ~ 60°C

ORDER CODE IGL8109



### 0.6 METER SPECIFICATIONS

MODEL Igloo Cube 0.6  
 ELECTRICITY 3kW, 220V, Single Phase  
 DIMENSIONS 610 x 840 x 1250mm high  
 WEIGHT 120kg  
 DISPLAY SURFACE 0.87m<sup>2</sup>  
 SHELF DIMENSIONS (1x) 570 x 425mm  
 (1x) 570 x 515mm  
 (1x) 580 x 525mm  
 TEMP RANGE 30 ~ 60°C

ORDER CODE IGL8106



## NEUTRAL DISPLAY CABINETS

### 0.9 METER SPECIFICATIONS

MODEL Igloo Cube 0.9  
 ELECTRICITY 0.3kW, 220V, Single Phase  
 DIMENSIONS 910 x 840 x 1250mm high  
 WEIGHT 160kg  
 DISPLAY SURFACE 1.3m<sup>2</sup>  
 SHELF DIMENSIONS (1x) 870 x 425mm  
 (1x) 870 x 515mm  
 (1x) 880 x 525mm

ORDER CODE IGL8209



### 0.6 METER SPECIFICATIONS

MODEL Igloo Cube 0.6  
 ELECTRICITY 0.3kW, 220V, Single Phase  
 DIMENSIONS 610 x 840 x 1250mm high  
 WEIGHT 110kg  
 DISPLAY SURFACE 0.87m<sup>2</sup>  
 SHELF DIMENSIONS (1x) 570 x 425mm  
 (1x) 570 x 515mm  
 (1x) 580 x 525mm

ORDER CODE IGL8206



## FEATURES

- Internal heated / cooling aggregate
- Front panel manufactured from stainless steel
- Glass side panel
- Back sliding doors with combined glass
- Automatic defrost on refrigerated unit
- Fitted with height adjustable feet
- External housing manufactured from stainless steel
- 3 Glass shelves with height and angle adjustable frames
- Internal top and each shelf illuminated with LED lights
- Electronic temperature controller with digital display
- High displays also available in self-help units with doors on both sides



## REFRIGERATED DISPLAY CABINETS

### 1.3 METER SPECIFICATIONS

**MODEL** Igloo Cube 1.3 H  
**ELECTRICITY** 0.3kW, 220V, Single Phase  
**DIMENSIONS** 1310 x 840 x 1380mm high  
**WEIGHT** 230kg  
**DISPLAY SURFACE** 2.3m<sup>2</sup>  
**SHELF DIMENSIONS**  
 (1x) 1280 x 345mm  
 (1x) 1280 x 425mm  
 (1x) 1280 x 515mm  
 (1x) 1290 x 525mm  
  
**TEMP RANGE** 5 ~ 15°C  
**REFRIGERANT GAS** R134a

**ORDER CODE** IGL8013-H



### 0.9 METER SPECIFICATIONS

**MODEL** Igloo Cube 0.9 H  
**ELECTRICITY** 0.3kW, 220V, Single Phase  
**DIMENSIONS** 910 x 840 x 1380mm high  
**WEIGHT** 130kg  
**DISPLAY SURFACE** 1.6m<sup>2</sup>  
**SHELF DIMENSIONS**  
 (1x) 870 x 345mm  
 (1x) 870 x 425mm  
 (1x) 870 x 515mm  
 (1x) 880 x 525mm  
  
**TEMP RANGE** 5 ~ 15°C  
**REFRIGERANT GAS** R134a

**ORDER CODE** IGL8009-H



**HEATED DISPLAY CABINETS**

**1.3 METER**

**SPECIFICATIONS**

MODEL Igloo Cube 1.3 H  
 ELECTRICITY 3kW, 220V, Single Phase  
 DIMENSIONS 1310 x 840 x 1380mm high  
 WEIGHT 230kg  
 DISPLAY SURFACE 2.3m<sup>2</sup>  
 SHELF DIMENSIONS  
 (1x) 1280 x 345mm  
 (1x) 1280 x 425mm  
 (1x) 1280 x 515mm  
 (1x) 1290 x 525mm  
 TEMP RANGE 30 ~ 60°C

**ORDER CODE**

**IGL8113-H**



**0.9 METER**

**SPECIFICATIONS**

MODEL Igloo Cube 0.9 H  
 ELECTRICITY 3kW, 220V, Single Phase  
 DIMENSIONS 910 x 840 x 1380mm high  
 WEIGHT 130kg  
 DISPLAY SURFACE 1.6m<sup>2</sup>  
 SHELF DIMENSIONS  
 (1x) 870 x 345mm  
 (1x) 870 x 425mm  
 (1x) 870 x 515mm  
 (1x) 880 x 525mm  
 TEMP RANGE 30 ~ 60°C

**ORDER CODE**

**IGL8109-H**



**0.9 METER - SELF HELP**

**SPECIFICATIONS**

MODEL Igloo Cube 0.9 H/SH  
 ELECTRICITY 3kW, 220V, Single Phase  
 DIMENSIONS 910 x 840 x 1380mm high  
 WEIGHT 180kg  
 DISPLAY SURFACE 1.6m<sup>2</sup>  
 SHELF DIMENSIONS  
 (1x) 870 x 345mm  
 (1x) 870 x 425mm  
 (1x) 870 x 515mm  
 (1x) 880 x 525mm  
 TEMP RANGE 30 ~ 60°C

**ORDER CODE**

**IGL8109-SH/H**



**NEUTRAL DISPLAY CABINETS**

**0.9 METER**

**SPECIFICATIONS**

MODEL Igloo Cube 0.9 H  
 ELECTRICITY 0.3kW, 220V, Single Phase  
 DIMENSIONS 910 x 840 x 1380mm high  
 WEIGHT 120kg  
 DISPLAY SURFACE 1.6m<sup>2</sup>  
 SHELF DIMENSIONS (1x) 870 x 345mm  
 (1x) 870 x 425mm  
 (1x) 870 x 515mm  
 (1x) 880 x 525mm

**ORDER CODE**

**IGL8209-H**



**0.9 METER - SELF HELP**

**SPECIFICATIONS**

MODEL Igloo Cube 0.9 H/SH  
 ELECTRICITY 0.3kW, 220V, Single Phase  
 DIMENSIONS 910 x 840 x 1380mm high  
 WEIGHT 170kg  
 DISPLAY SURFACE 1.6m<sup>2</sup>  
 SHELF DIMENSIONS  
 (1x) 870 x 345mm  
 (1x) 870 x 425mm  
 (1x) 870 x 515mm  
 (1x) 880 x 525mm

**ORDER CODE**

**IGL8209-SH/H**



## FEATURES

- Straight front, top and side glass
- Optional self help front glass available
- Illuminated by LED lighting below top glass
- Designed to be fitted on counter top (not on appliance)

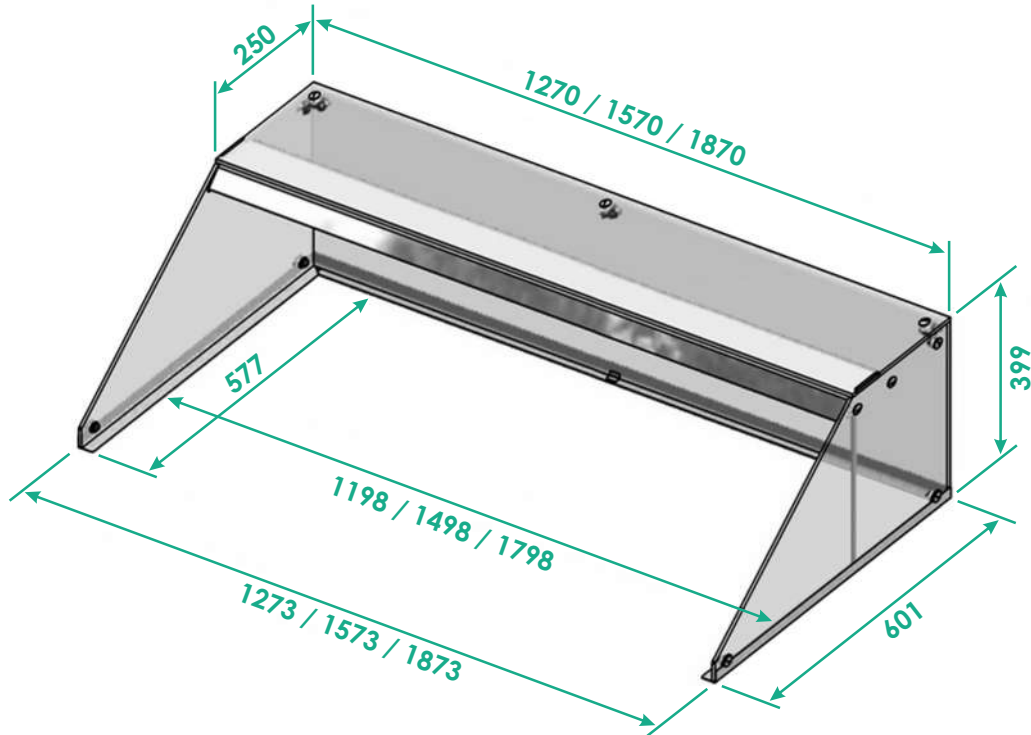

## SQUARE GLASS 1800mm

### SPECIFICATIONS

MODEL	Igloo Gastroline
ELECTRICITY	220V, Single Phase
DIMENSIONS	1800 x 600 x 400mm high
WEIGHT	40kg
CUT SIZE	1800 x 660mm

ORDER CODE **IGL8818**

## SELF HELP FRONT GLASS 1800mm

ORDER CODE **IGL8818-SH**

## SQUARE GLASS 1500mm

### SPECIFICATIONS

MODEL	Igloo Gastroline
ELECTRICITY	220V, Single Phase
DIMENSIONS	1500 x 600 x 400mm high
WEIGHT	35kg
CUT SIZE	1500 x 660mm

ORDER CODE **IGL8815**

### SPECIFICATIONS

MODEL	Igloo Gastroline
ELECTRICITY	220V, Single Phase
DIMENSIONS	1200 x 600 x 400mm high
WEIGHT	30kg
CUT SIZE	1200 x 660mm

ORDER CODE **IGL8812**

## SELF HELP FRONT GLASS 1200mm

ORDER CODE **IGL8812-SH**





## FEATURES

- Internal cooling aggregate
- Ecological polyurethane foam insulation
- Fitted with night roller blind
- ABS side panels with glass thickness 40mm
- Automatic defrost
- Fitted with device levelling legs
- Dynamic cooling (ventilated)
- Internal top illuminated - LED light (white colour)
- Exposition shelves with height and angle adjustment
- Electronic temperature controller with digital display
- Condenser impurity or fan operation failure alarm
- Available in black or stainless steel models



## 2.5 METER

### SPECIFICATIONS

MODEL Igloo Paros 2.5  
 ELECTRICITY 1.8kW, 220V, Single Phase  
 DIMENSIONS 2540 x 695 x 2020mm high  
 WEIGHT 340kg  
 DISPLAY SURFACE 4.5m<sup>2</sup>  
 SHELF DIM (8x) 1280 x 345mm  
 (1x) 2460 x 425mm  
 TEMP RANGE 3 ~ 10°C  
 REFRIGERANT GAS R404a

STAINLESS STEEL

IGL9025



## 1.9 METER

### SPECIFICATIONS

MODEL Igloo Paros 1.9  
 ELECTRICITY 1.4kW, 220V, Single Phase  
 DIMENSIONS 1910 x 695 x 2020mm high  
 WEIGHT 290kg  
 DISPLAY SURFACE 3.4m<sup>2</sup>  
 SHELF DIM (4x) 1800 x 360mm  
 (1x) 1800 x 440mm  
 TEMP RANGE 3 ~ 10°C  
 REFRIGERANT GAS R134a

STAINLESS STEEL

IGL9019



## 1.3 METER

### SPECIFICATIONS

MODEL Igloo Paros 1.3  
 ELECTRICITY 1.13kW, 220V, Single Phase  
 DIMENSIONS 1310 x 695 x 2020mm high  
 WEIGHT 190kg  
 DISPLAY SURFACE 2.2m<sup>2</sup>  
 SHELF DIM (4x) 1200 x 360mm  
 (1x) 1200 x 440mm  
 TEMP RANGE 3 ~ 10°C  
 REFRIGERANT GAS R134a

STAINLESS STEEL  
 BLACK

IGL9013  
 IGL9013-B



## 1 METER

### SPECIFICATIONS

MODEL Igloo Paros 1.0  
 ELECTRICITY 1.1kW, 220V, Single Phase  
 DIMENSIONS 1010 x 695 x 2020mm high  
 WEIGHT 160kg  
 DISPLAY SURFACE 1.7m<sup>2</sup>  
 SHELF DIM (4x) 900 x 360mm  
 (1x) 900 x 440mm  
 TEMP RANGE 3 ~ 10°C  
 REFRIGERANT GAS R134a

STAINLESS STEEL  
 BLACK

IGL9010  
 IGL9010-B





**FEATURES**

- Internal cooling aggregate
- Dynamic cooling temperature range 2°C ~ 10°C
- Glass exposition shelves
- Ecological polyurethane foam insulation
- Side glass with silk screen printing
- External housing, interior and frame made of powder painted steel
- Upper interior lighting + additional illumination of each shelf - LED lights (confectionery color)
- Automatic defrost
- Automatic condenser vaporization
- Electronic temperature controller with digital display (IGLOO)
- Condenser impurity or fan operation failure alarm
- External housing made of stainless steel
- Interior and frame made of stainless steel sheet
- Exposition shelves on frame made of powder painted steel
- Exposition shelves on frame made of stainless steel
- Electronic temperature recorder + software
- Temperature recorder wire (RS232 USB)

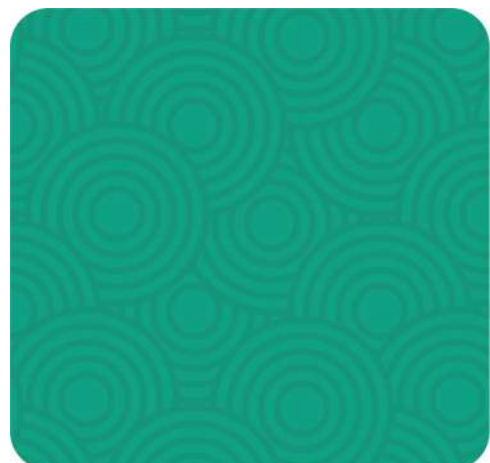

**REFRIGERATED MERCHANDISERS**



**0.9 METER SPECIFICATIONS**

MODEL Igloo Petro Select PR101S  
 ELECTRICITY 0.76kW, 220V, Single Phase  
 DIMENSIONS 900 x 725 x 1400mm high  
 WEIGHT 170kg  
 DISPLAY SURFACE 1.2m<sup>2</sup>  
 TEMP RANGE 2 ~ 10°C  
 REFRIGERANT R134a

ORDER CODE IGL3009



**0.6 METER SPECIFICATIONS**

MODEL Igloo Petro Select PR100S  
 ELECTRICITY 0.35kW, 230V, Single Phase  
 DIMENSIONS 600 x 725 x 1400mm high  
 WEIGHT 125kg  
 DISPLAY SURFACE 0.8m<sup>2</sup>  
 TEMP RANGE 2 ~ 10°C  
 REFRIGERANT R134a

ORDER CODE IGL3006



**90° NEUTRAL CORNER UNITS**



**LEFT SPECIFICATIONS**

MODEL Igloo Petro PRSNZ90NL  
 DIMENSIONS 425 x 725 x 1400mm high  
 WEIGHT 30kg  
 DISPLAY SURFACE 0.6m<sup>2</sup>

ORDER CODE IGL3001



**RIGHT SPECIFICATIONS**

MODEL Igloo Petro PRSNZ90NP  
 DIMENSIONS 425 x 725 x 1400mm high  
 WEIGHT 30kg  
 DISPLAY SURFACE 0.6m<sup>2</sup>

ORDER CODE IGL3002

# ICE CREAM SCOOP FREEZERS TABLE MODEL

*Galileo*

## FEATURES

- Stainless steel exterior and interior finish with tempered glass
- Fan assisted cooling
- Digital controller and temperature display
- Removable sliding door for easy cleaning
- Fully automatic
- Fan assisted condenser
- Interior LED light with switch
- Removable door gasket



## 5 DIVISION

### SPECIFICATIONS

MODEL Galileo TSF-120  
 ELECTRICITY 0.75kW, 230V, Single Phase  
 DIMENSIONS 1200 x 550 x 790mm high  
 WEIGHT 140kg  
 CAPACITY (5x) 1/3 GN inserts - 100mm  
 TEMPERATURE RANGE -18 ~ -12°C  
 REFRIGERANT GAS R404A

ORDER CODE

IFG/TSF-120



## 3 DIVISION

### SPECIFICATIONS

MODEL Galileo TSF-90  
 ELECTRICITY 0.65kW, 230V, Single Phase  
 DIMENSIONS 900 x 550 x 790mm high  
 WEIGHT 120kg  
 CAPACITY (3x) 1/3 GN inserts - 100mm  
 TEMPERATURE RANGE -18 ~ -12°C  
 REFRIGERANT GAS R404A

ORDER CODE

IFG/TSF-90



- FEATURES**
- Compact design to minimize footprint
  - Low maintenance auto defrost function
  - Fitted with digital temperature controller
  - Glass panels are easy to remove for cleaning
  - Can accommodate 1/4 and 1/2 GN pans
  - GN pans not included



## 8 DIVISION 1/4 GN

### SPECIFICATIONS

MODEL PolarCab ESL 3888  
 ELECTRICITY 3kW, 230V, Single Phase  
 DIMENSIONS 1805 x 395 x 420mm high  
 WEIGHT 53kg  
 CAPACITY (8x) 1/4 GN pans  
 (4x) 1/2 GN pans  
 TEMP RANGE 2 ~ 8°C  
 REFRIGERANT GAS R134a

ORDER CODE

PCY/ESL3888



## 6 DIVISION 1/4 GN

### SPECIFICATIONS

MODEL PolarCab ESL 3861  
 ELECTRICITY 3kW, 230V, Single Phase  
 DIMENSIONS 1405 x 395 x 465mm high  
 WEIGHT 41kg  
 CAPACITY (6x) 1/4 GN pans  
 (3x) 1/2 GN pans  
 TEMP RANGE 2 ~ 8°C  
 REFRIGERANT GAS R134a

ORDER CODE

PCY/ESL3861



**FEATURES**

- Powder coated stainless steel exterior
- Front and rear sliding doors provide quick, easy access
- Internal lighting
- Front mounted temperature gauge for monitoring temperature
- Thermostatically controlled heater
- 430 Grade stainless steel interior and shelving racks
- Glass side panels for optimum display
- Humidity pan prevents drying out
- Adjustable shelves
- Fitted with (4x) non-slip feet



**900mm**

**SPECIFICATIONS**

MODEL	SmartChef HW-60-2
ELECTRICITY	1.84kW, 220V, Single Phase
DIMENSIONS	900 x 480 x 610mm high
WEIGHT	50kg
TEMP RANGE	50 ~ 90°C
SHELF DIMENSIONS	(3x) 815 x 360mm

**ORDER CODE** PWS0002



**660mm**

**SPECIFICATIONS**

MODEL	SmartChef HW-60-1
ELECTRICITY	1.84kW, 220V, Single Phase
DIMENSIONS	660 x 480 x 610mm high
WEIGHT	33kg
TEMP RANGE	50 ~ 90°C
SHELF DIMENSIONS	(3x) 575 x 360mm

**ORDER CODE** PWS0001

**FEATURES**

- Manufactured from 430 Grade stainless steel
- Internal lighting
- Adjustable shelves
- Thermostatically controlled heater
- Front sliding glass doors
- Humidity pan prevents drying out
- Front mounted temperature gauge for monitoring temperature
- Fitted with (4x) non-slip feet



**640mm**

**SPECIFICATIONS**

MODEL	SmartChef HW-580
ELECTRICITY	1kW, 220V, Single Phase
DIMENSIONS	640 x 360 x 530mm high
WEIGHT	45kg
TEMP RANGE	50 ~ 90°C
SHELF DIMENSIONS	(4x) 565 x 300mm

**ORDER CODE** PWS0004



# Galileo



Elegant Retail Display Cabinets

# FURMIS



**SUPERIOR**  
pizza and meal  
delivery bags





## SECTION INDEX

Baking trolleys .....	184
Beverage containers .....	177
CamTrays .....	173
Cleaning trolleys .....	115
Delivery bags .....	174-175
Delivery boxes .....	176
Food pan carriers .....	177-180
Food serving carts .....	172
GoBoxes .....	179-180
Insulated bases & domes .....	173
Insulated meal delivery system .....	173
Meal delivery bags .....	174-175
Meal delivery boxes .....	176
Meal delivery carts .....	170-171
Pizza delivery bags .....	174-175
Rack trolleys .....	184-185
Serving trays .....	173
Tea trolleys .....	182-183
Tray clearing trolleys .....	181

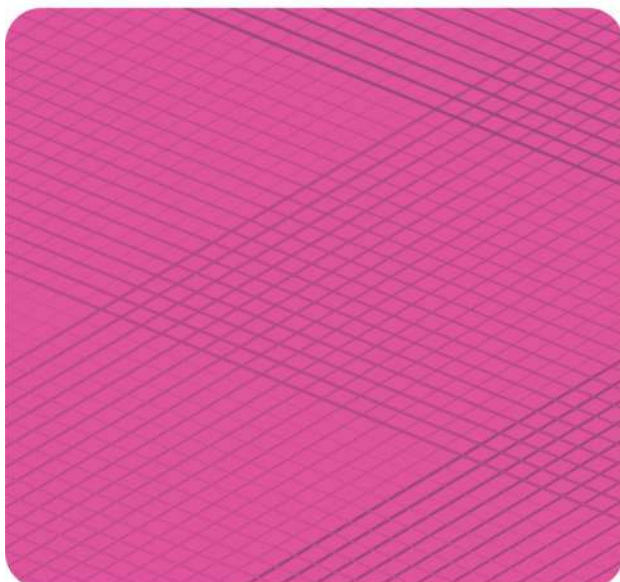



**FEATURES**

- Thick, high quality CFC-free foam insulation protects hot or cold meals
- Designed from one-piece double wall polyethylene for durability
- Lightweight doors open a full 270° for fast, quiet access to trays
- Molded-in rails spaced 127mm ensure quiet meal delivery
- Heavy duty nylon handles securely mounted on each end
- Five menu clips hold routing directions or content lists
- Fitted with stainless steel door latches
- Rust, dent, crack, chip, and break resistant
- Non-electric and requires no assembly
- Fitted with 6 heavy duty nylon casters (2 rigid, 4 swivel with brake)

**30 TRAY**

**SPECIFICATIONS**

MODEL	CAMBRO MDC1520T30
DIMENSIONS	1524 x 743 x 1616mm high
INTERIOR DIMENSIONS	(3x) 390 x 533 x 1270mm high
WEIGHT	95kg
COMPARTMENTS	3
RAIL SPACING	127mm
CAPACITY	(30x) 380 x 515mm trays

**ORDER CODE**

**CAM-MDC1520T30**

HOLDING & DISTRIBUTION



**HEAVY DUTY NYLON HANDLES**



**SECURITY DOOR LATCHES**



**SMOOTH RUNNING CASTORS**

## FEATURES

- Holds multiple trays of plated food
- Hidden friction catch on each door for easy closing
- Molded in handles on each end for smooth transporting
- Easy to clean and won't rust, dent, crack, chip or break
- Fitted with 5 sets of rails per compartment – Fits 2 trays per rail
- Rail spacing holds all standard tray set-ups with clearances up to 140mm high
- Two castor configuration offer excellent stability and smooth transporting
- Camtrays not included
- Made of tough, one-piece, double-wall polyethylene
- Two internal nylon friction latches
- Menu clip on each door reduces need to open door



## 20 TRAY SPECIFICATIONS

MODEL	Cambro MDC1520S20
DIMENSIONS	1400 x 965 x 1125mm high
INTERNAL DIMENSIONS	(2x) 520 x 770 x 700mm high
WEIGHT	71kg
COMPARTMENTS	2
RAIL SPACING	139mm
CAPACITY	(20x) Trays (10x) Trays per compartment (2x) Trays per rail

ORDER CODE

**CAM-MDC1520S20**



## 10 TRAY SPECIFICATIONS

MODEL	Cambro MDC1520S10
DIMENSIONS	750 x 980 x 1080mm high
WEIGHT	40kg
INTERNAL DIMENSIONS	535 x 787 x 670mm high
COMPARTMENTS	1
RAIL SPACING	133mm
CAPACITY	(10x) Trays (2x) Trays per rail

ORDER CODE

**CAM-MDC1520S10**





**FEATURES**

- Constructed from light weight material
- Fitted with push handles
- Fitted with heavy duty swivel castors, 2 with brakes
- Modular design for east replacement in case of damaged parts
- Fitted with removable latched doors

**24 TRAY TROLLEY**

**SPECIFICATIONS**

MODEL TrayPort 1100-T3D-39  
 DIMENSIONS 1500 x 750 x 1250mm high  
 WEIGHT 60kg  
 CAPACITY (3x) 8 Trays  
 TRAY SIZE 380 x 525mm (Tuff Tray No.14)  
 380 x 515mm (Camtray 1520)  
 RUNNER SPACE 120mm

ORDER CODE **PLA-1100-T3D-39**



**16 TRAY TROLLEY**

**SPECIFICATIONS**

MODEL TrayPort 1100-D3D-39  
 DIMENSIONS 1000 x 750 x 1250mm high  
 WEIGHT 40kg  
 CAPACITY (2x) 8 Trays  
 TRAY SIZE 380 x 525mm (Tuff Tray No.14)  
 380 x 515mm (Camtray 1520)  
 RUNNER SPACE 120mm

ORDER CODE **PLA-1100-D3D-39**



**8 TRAY TROLLEY**

**SPECIFICATIONS**

MODEL TrayPort 1100-S3D-39  
 DIMENSIONS 500 x 750 x 1250mm high  
 WEIGHT 20kg  
 CAPACITY 8 Trays  
 TRAY SIZE 380 x 525mm (Tuff Tray No.14)  
 380 x 515mm (Camtray 1520)  
 RUNNER SPACE 120mm

ORDER CODE **PLA-1100-S3D-39**





**INSULATED DOME COVERS**

DIMENSIONS 260 x 70mm high  
 INTERNAL HEIGHT 50mm  
 ORDER CODE CAM-MDSL9



**INSULATED BASE**

INSULATED BASE FOR 23cm PLATE  
 ORDER CODE CAM-HK39B



**CAMTRAYS**

DIMENSIONS 355 x 457mm  
 ORDER CODE CAM-1418

DIMENSIONS 380 x 510mm  
 ORDER CODE CAM-1520



**NON-SLIP SURFACE**

## FEATURES

- Manufactured from durable, easy washable Nylon material
- Patented 'CLICKBYCLICK' closing system based on plates and magnets sewn into the bag
- Fitted with side pockets for drinks
- Fitted with a transparent pocket for bills
- Stiffening frame and 12V heating pad available as optional extras



### 8 x PIZZA BAG SPECIFICATIONS

MODEL	Furmis T8S
DIMENSIONS	400 x 400 x 420mm high
INTERNAL DIMENSIONS	360 x 360 x 400mm high
CAPACITY	(8x) 350 x 350mm boxes

ORDER CODE **FUR-T8S-NM**



### 4 x PIZZA BAG SPECIFICATIONS

MODEL	Furmis T4S
DIMENSIONS	400 x 400 x 250mm high
INTERNAL DIMENSIONS	360 x 360 x 210mm high
CAPACITY	(4x) 350 x 350mm boxes

ORDER CODE **FUR-T4S-NM**

## OPTIONAL EXTRAS



### 12V HEATING PAD SPECIFICATIONS

MODEL	Furmis HP-TS
ELECTRICITY	12V

ORDER CODE **FUR-HP-TS**

*\*Supplied with 2.5m power cord*

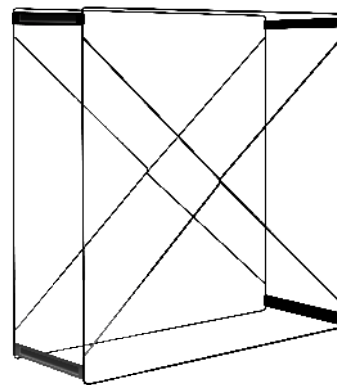

**STIFFENING FRAME FOR T8S**  
ORDER CODE **FUR-T8S-FRAME**

**STIFFENING FRAME FOR T4S**  
ORDER CODE **FUR-T4S-FRAME**

## FEATURES

- Manufactured from durable, easy washable Nylon material
- Patented 'CLICKBYCLICK' closing system based on plates and magnets sewn into the bag
- Stiffened bottom
- Fitted with side pockets for drinks
- Fitted with a transparent pocket for bills



### 12 x MEAL BAG SPECIFICATIONS

MODEL Furmis LUNCHBOX-12  
 DIMENSIONS 540 x 470 x 270mm high  
 INTERNAL DIMENSIONS 520 x 450 x 250mm high  
 CAPACITY (12x) 200 x 250mm containers

ORDER CODE **FUR-LB12-NM**



### 6 x MEAL BAG SPECIFICATIONS

MODEL Furmis LUNCHBOX-6  
 DIMENSIONS 450 x 300 x 320mm high  
 INTERNAL DIMENSIONS 420 x 270 x 290mm high  
 CAPACITY (6x) 200 x 250mm containers

ORDER CODE **FUR-LB6-NM**

## ECONO PIZZA BAG

### FEATURES

- Manufactured from durable, easy washable Nylon material
- Fitted with a transparent pocket for bills
- Velcro closing system
- Fitted with side pockets for drinks



### 4 x MEAL BAG SPECIFICATIONS

MODEL Furmis ECO S  
 DIMENSIONS 400 x 400 x 240mm high  
 INTERNAL DIMENSIONS 370 x 370 x 220mm high  
 CAPACITY (4x) 350 x 350mm containers

ORDER CODE **FUR-ECO-S**

## FEATURES

- Manufactured from lightweight, odorless, non-toxic plastic
- Durable & long-lasting
- Perfect heat insulation keeps products warm for longer
- The cover is fitted with hydraulic arms for easy loading and unloading
- Fitted with a durable safety latch to ensure that the lid remains sealed
- Fitted with durable hinges
- Easily to clean
- Specially designed to be fitted on most motorcycle brands
- The product increases your prestige in front of the customer during service



## PIZZA BOX (FRONT LOADING)

### SPECIFICATIONS

MODEL	Avatherm AVA-100305
OUTER DIMENSIONS	600 x 460 x 375mm high
INNER DIMENSIONS	460 x 460 x 330mm high
VOLUME	70Lt
WEIGHT	7.2kg

ORDER CODE AVA-100305



## THERMOBOX 640 (TOP LOADING)

### SPECIFICATIONS

MODEL	Avatherm AVA-100275
OUTER DIMENSIONS	600 x 470 x 375mm high
INNER DIMENSIONS	530 x 380 x 270mm high
VOLUME	54Lt
WEIGHT	6.6kg

ORDER CODE AVA-100275





## FEATURES

- Holds multiple pans of hot or cold food for up to 4 hours
- Door removes for easy cleaning
- Menu clip reduces need to open door
- Built-in seal eliminates need for removable gasket
- 'Sta-Stack' interlocking ensures stable stacking during transport and storage
- Durable polyethylene shell and thick polyurethane foam insulation
- Integrated pan-staging area eases service
- Robust, molded-in handles for comfortable two-person carrying
- Single 23cm nylon latch for quick and secure opening and closing



## 6 PAN FRONT LOADING

### SPECIFICATIONS

MODEL	Cambro Ultra Camcart UPC400
DIMENSIONS	425 x 620 x 570mm high
WEIGHT	16kg
INTERNAL DIMENSIONS	340 x 535 x 360mm high
CAPACITY	(6x) 65mm deep 1/1 GN pans (4x) 100mm deep 1/1 GN pans (3x) 150mm deep 1/1 GN pans (2x) 200mm deep 1/1 GN pans Also holds 1/2 and 1/3 GN pans

ORDER CODE

CAM-UPC400

# INSULATED BEVERAGE CONTAINERS

## FEATURES

- Use to hold, transport and serve hot or cold beverages
- One piece, seamless double-wall polyethylene with thick foam insulation
- Wide nylon latches secure lids tightly to prevent spillage and will never rust
- Drip-proof recessed faucet accommodates larger cups and bowls for easy self-serve access
- Two position faucet - One for continuous pouring and one for individual dispensing
- Fitted with vent cap to equalise pressure for easy opening
- "Sta-Stack" interlocking ensures stable stacking during transport and storage



### Hot

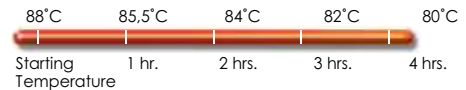

### Cold

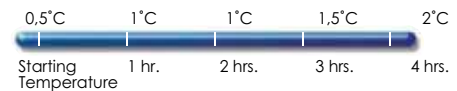

## 20 LITRE

### SPECIFICATIONS

MODEL	Cambro Ultra Container UC500
DIMENSIONS	425 x 300 x 680mm high
WEIGHT	9kg
CAPACITY	19.9Lt (96x) 210ml cups

ORDER CODE

CAM-UC500



## 10 LITRE

### SPECIFICATIONS

MODEL	Cambro Ultra Container UC250
DIMENSIONS	425 x 300 x 500mm high
WEIGHT	7kg
CAPACITY	10.4Lt (50x) 210ml cups

ORDER CODE

CAM-UC250





**FEATURES**

- Double walled and internally foamed with CFC-Free polyurethane, providing optimum insulation with high resistance
- Fulfill all requirements of the food hygiene regulation
- Easy stackable for transport allowing for the multiple distribution of goods
- Side handles provide a convenient reliable and highly accessible means of transportation
- Its highly accessible design makes it easy to clean
- Integrated menu card holder
- GN Pans not included

**6 PAN FRONT LOADING**

**SPECIFICATIONS**

MODEL	Avatherm 601 M
DIMENSIONS	450 x 625 x 575mm high
WEIGHT	10kg
INTERNAL DIMENSIONS	330 x 540 x 460mm high
LOAD CAPACITY	(6x) 65mm deep 1/1 GN pans (4x) 100mm deep 1/1 GN pans (3x) 150mm deep 1/1 GN pans Also holds 1/2 & 1/3 GN pans



ORDER CODE   
 ORDER CODE

**AVA-100155-HD**  
**AVA-100160-HD**



**LOADING EXAMPLE**

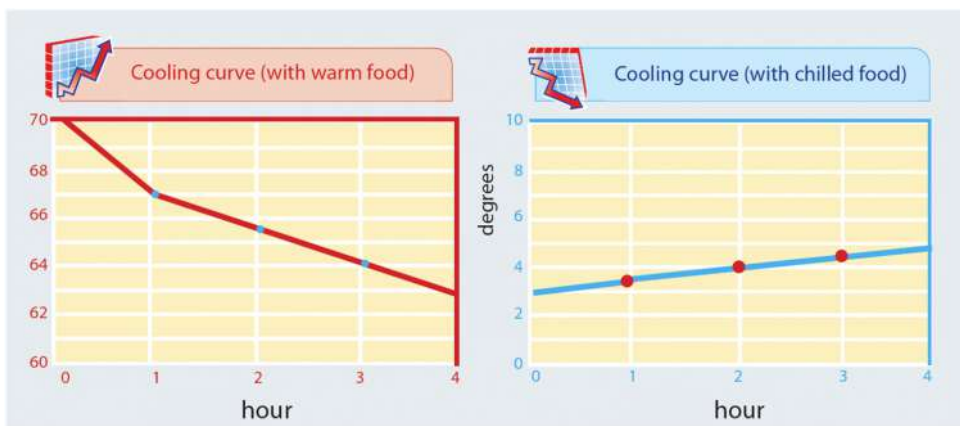

**FEATURES**

- Manufactured from CFC-free expanded polypropylene material
- Fits GN1/1, GN1/2 and GN1/3 containers
- Ergonomic handles for easy lifting and storage
- Door opens to allow 270° access for fast and safe service
- Stackable with other GoBoxes
- Withstands temperatures of -40°C to 120°C
- 100% Recyclable
- No electricity needed, goes anywhere!
- Weighs less than 4kg when empty
- Fitted with heavy duty door latches
- Resistant to most oil, grease, and chemicals
- Impact resistant for safe transport
- Dishwasher safe



**86 LITRE**  
**SPECIFICATIONS**

MODEL	GoBox EPP400
DIMENSIONS	640 x 440 x 625mm high
INTERIOR DIM.	535 x 330 x 525mm high
VOLUME	86Lt
WEIGHT	4kg
RUNNER SPACING	70mm

**ORDER CODE**                      **CAM-EPP400**

**EPP400**

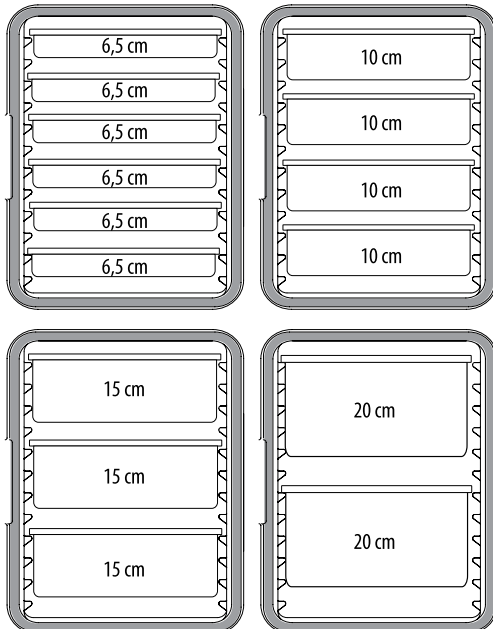

**60 LITRE**  
**SPECIFICATIONS**

MODEL	GoBox EPP300
DIMENSIONS	640 x 440 x 475mm high
INTERIOR DIM.	535 x 330 x 370mm high
VOLUME	60Lt
WEIGHT	3kg
RUNNER SPACING	70mm

**ORDER CODE**                      **CAM-EPP300**

**EPP300**

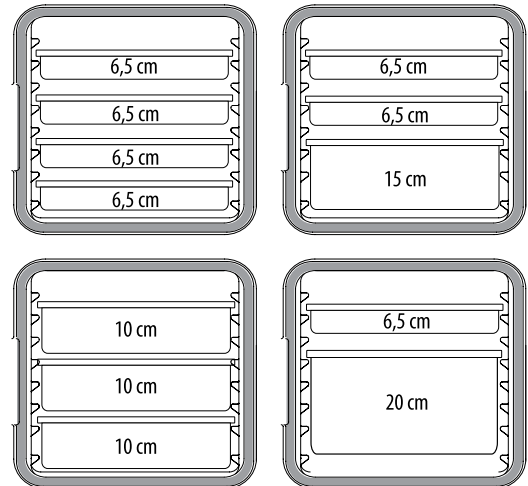

**FEATURES**

- Manufactured from CFC-free expanded polypropylene material
- Accommodates GN 1/1 containers
- Ergonomic handles for easy lifting and storage
- Stackable with other GoBoxes
- Withstands temperatures of -40°C to 120°C
- 100% Recyclable
- No electricity needed, goes anywhere!
- Weighs less than 2kg when empty
- Built in label area for menu tags
- Resistant to most oil, grease, and chemicals
- Impact resistant for safe transport
- Dishwasher safe



**46 LITRE SPECIFICATIONS**

MODEL	GoBox EPP180
DIMENSIONS	600 x 400 x 316mm high
INTERIOR DIM.	538 x 338 x 253mm high
VOLUME	46Lt
WEIGHT	1.5kg

ORDER CODE **CAM-EPP180**



**35 LITRE SPECIFICATIONS**

MODEL	GoBox EPP160
DIMENSIONS	600 x 400 x 257mm high
INTERIOR DIM.	538 x 338 x 193mm high
VOLUME	35.5Lt
WEIGHT	1kg

ORDER CODE **CAM-EPP160**

**EPP180**

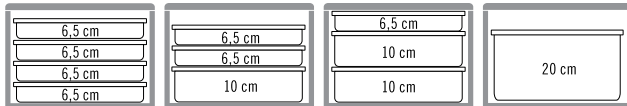

**EPP160**



**OPTIONAL EXTRAS**



**FEATURES**

- Add 100mm extra height to top loading GoBox
- Fits - EPP180 and EPP160

**GoBox TOP LOADER EXTENDER**

MODEL	CAMBRO EPPEXT
DIMENSIONS	399 x 594 x 99mm high
WEIGHT	0.24kg

ORDER CODE **CAM-EPPEXT**



**FEATURES**

- Manufactured with durable plastic
- Plastic will not crack, dent, rust or corrode
- Features (4x) heavy duty casters - 2 lockable
- Suitable for use with front or top loading GoBox

**GoBox DOLLIES**

MODEL	CAMBRO CD3253EPP
DIMENSIONS	400 x 600 x 170mm high
WEIGHT	4.5kg

ORDER CODE **CAM-CD3253EPP**



**FEATURES**

- Constructed from light weight material
- Modular design for easy replacement in case of damaged parts
- Holds up to 30 trays
- Fitted with heavy duty swivel castors, 2 with brakes

**30 TRAY TROLLEY**

**SPECIFICATIONS**

MODEL	TrayPort 1150-D2-39
DIMENSIONS	1000 x 750 x 1750mm high
WEIGHT	37kg
CAPACITY	(2x) 15 Trays
TRAY SIZE	380 x 525mm (Tuff Tray No.14) 380 x 515mm (Camtray 1520)
RUNNER SPACING	100mm

**ORDER CODE**

**PLA-1150-D2-39**

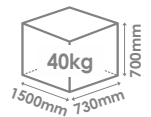

**15 TRAY TROLLEY**

**SPECIFICATIONS**

MODEL	TrayPort 1150-S2-39
DIMENSIONS	500 x 750 x 1750mm high
WEIGHT	19kg
CAPACITY	15 Trays
TRAY SIZE	380 x 525mm (Tuff Tray No.14) 380 x 515mm (Camtray 1520)
RUNNER SPACING	100mm

**ORDER CODE**

**PLA-1150-S2-39**



## FEATURES

- Stainless steel tubular frame
- Easy to assemble
- Fitted with 100mm diameter swivel castors



### 3 TIER

#### SPECIFICATIONS

MODEL	SmartChef RPD-M3
DIMENSIONS	850 x 540 x 900mm high
WEIGHT	15kg
SHELF DIMENSIONS	(3x) 830 x 430mm high

**ORDER CODE** TTT1003



### 2 TIER

#### SPECIFICATIONS

MODEL	SmartChef RPD-M2
DIMENSIONS	850 x 540 x 900mm high
WEIGHT	13kg
SHELF DIMENSIONS	(2x) 830 x 430mm high

**ORDER CODE** TTT1002



## DISH & TOTE HOLDER



#### SPECIFICATIONS

DIMENSIONS 500 x 400 x 130mm deep

**ORDER CODE** DTH0001



### FEATURES

- Tiers manufactured from durable plastic
- Pillars manufactured from aluminium
- Light weight and soft in motion
- Easy to assemble
- Fitted with (4x) swivel castors

### 3 TIER - WITH BINS

#### SPECIFICATIONS

MODEL	SmartChef ACD-012A
DIMENSIONS	1030 x 510 x 1030mm high
WEIGHT	17kg
SHELF DIMENSIONS	(3x) 1000 x 500mm

ORDER CODE **TTP0001**

### 3 TIER - NO BINS

#### SPECIFICATIONS

MODEL	SmartChef ACD-012A
DIMENSIONS	1030 x 510 x 1030mm high
WEIGHT	17kg
SHELF DIMENSIONS	(3x) 1000 x 500mm

ORDER CODE **TTP0000**



## OPTIONAL SIDE BINS



### LARGE

#### SPECIFICATIONS

MODEL	SmartChef TTP0011
DIMENSIONS	330 x 240 x 560mm high

ORDER CODE **TTP0011**

### SMALL

#### SPECIFICATIONS

MODEL	SmartChef TTP0012
DIMENSIONS	330 x 240 x 170mm high

ORDER CODE **TTP0012**





### FEATURES

- Manufactured from high quality stainless steel
- Fitted with (4x) castors. 2 with brakes
- Assembly required (Supplied flat packed)

## 15 TIER BAKING TROLLEY

### SPECIFICATIONS

MODEL	SmartChef BTT1-15-64
DIMENSIONS	470 x 620 x 1700mm high
WEIGHT	22kg
COMPATIBILITY	400 x 600mm baking trays
RUNNER SPACING	80mm

ORDER CODE **BTT1-15-64**



## 7 TIER BAKING TROLLEY

### SPECIFICATIONS

MODEL	SmartChef BTT1-7-64
DIMENSIONS	740 x 550 x 1700mm high
WEIGHT	13kg
COMPATIBILITY	400 x 600mm baking trays
RUNNER SPACING	220mm

ORDER CODE **BTT1-7-64**



# STAINLESS STEEL MULTI-FUNCTION RACK TROLLEY



### FEATURES

- Manufactured from high quality stainless steel
- Shelf locking mechanisms on both openings
- Fitted with (4x) castors. 2 with brakes
- Assembly required (Supplied flat packed)

## 18 TIER RACK TROLLEY

### SPECIFICATIONS

MODEL	SmartChef GNT1-18-16
DIMENSIONS	530 x 660 x 1740mm high
WEIGHT	29kg
COMPATIBILITY	1/1 GN Pans
RUNNER SPACING	400 x 600mm baking trays
RUNNER SPACING	80mm

ORDER CODE **GNT1-18-16**



**ACCOMMODATES GN PANS & BAKING TRAYS**





## FEATURES

- Manufactured from high quality stainless steel
- Shelf locking mechanisms on both openings
- Fitted with (4x) castors. 2 with brakes
- Assembly required (Supplied flat packed)

## 16 TIER DOUBLE RACK TROLLEY

### SPECIFICATIONS

MODEL SmartChef GNT2-16-11  
 DIMENSIONS 800 x 620 x 1705mm high  
 WEIGHT 33kg  
 COMPATIBILITY 1/1 GN Pans  
 RUNNER SPACING 80mm

ORDER CODE

GNT2-16-11



## 7 TIER DOUBLE RACK TROLLEY WITH WORK TOP

### SPECIFICATIONS

MODEL SmartChef GNT2-7-11  
 DIMENSIONS 740 x 550 x 950mm high  
 WEIGHT 24kg  
 COMPATIBILITY 1/1 GN Pans  
 RUNNER SPACING 80mm

ORDER CODE

GNT2-7-11



## 7 TIER RACK TROLLEY WITH WORK TOP

### SPECIFICATIONS

MODEL SmartChef GNT1-7-11  
 DIMENSIONS 380 x 550 x 950mm high  
 WEIGHT 14kg  
 COMPATIBILITY 1/1 GN Pans  
 RUNNER SPACING 80mm

ORDER CODE

GNT1-7-11

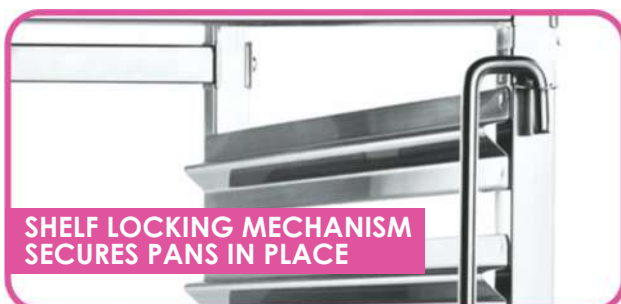

**SHELF LOCKING MECHANISM SECURES PANS IN PLACE**



**STAINLESS STEEL WORK TOP ADDS ADDITIONAL FUNCTIONALITY**



***SmartChef***

**CHROME WIRE SHELVING**

## SECTION INDEX

Chrome shelving .....	188
Inserts & lids .....	190-193
Kitchen scales .....	195
Plate shelf .....	189
Platform scales .....	194
Portion scales .....	194-195
Retail scales .....	195
<i>Scales</i>	
• Platform scales .....	194
• Portion scales .....	194-195
• Retail scales .....	195
<i>Shelving</i>	
• Chrome shelves .....	188
• Spice shelf .....	189
• Plate shelf .....	189
Spice shelf .....	189
Ticket holders .....	189
Wall mounted shelving .....	189





### FEATURES

- Shelves are manufactured from chrome plated steel
- Easy to assemble – no tools needed
- Sturdy construction makes them durable and versatile
- Shelf heights can be adjusted to suit your application
- Grid style shelves allow increased air circulation, prolonging the life of products
- Fitted with adjustable, unit leveling legs



**ADJUSTABLE SHELF HEIGHT**



**STURDY UNIT LEVELING LEGS**

### 4 TIER, 1800mm

#### SPECIFICATIONS

MODEL SmartChef CJ1800  
 DIMENSIONS 1800 x 450 x 1800mm high  
 WEIGHT 20kg  
 SHELF DIMENSIONS 1800 x 450mm

ORDER CODE

SCS1800



### 4 TIER, 1500mm

#### SPECIFICATIONS

MODEL SmartChef CJ1500  
 DIMENSIONS 1500 x 450 x 1800mm high  
 WEIGHT 15kg  
 SHELF DIMENSIONS 1500 x 450mm

ORDER CODE

SCS1500



### 4 TIER, 1200mm

#### SPECIFICATIONS

MODEL SmartChef CJ1200  
 DIMENSIONS 1200 x 450 x 1800mm high  
 WEIGHT 10kg  
 SHELF DIMENSIONS 1200 x 450mm

ORDER CODE

SCS1200



### 4 TIER, 900mm

#### SPECIFICATIONS

MODEL SmartChef CJ900  
 DIMENSIONS 900 x 450 x 1800mm high  
 WEIGHT 8kg  
 SHELF DIMENSIONS 900 x 450mm

ORDER CODE

SCS0900



## ADDITIONAL SHELVING



**1800mm**

ORDER CODE

SCS1801

**1500mm**

ORDER CODE

SCS1501

**1200mm**

ORDER CODE

SCS1201

**900mm**

ORDER CODE

SCS0901

# WALL MOUNTED STAINLESS STEEL KITCHEN ACCESSORIES

## WALL MOUNTED SPICE SHELF FOR GN 1/6 PANS



### FEATURES

- Manufactured from high quality stainless steel
- GN Pans not included

### SPECIFICATIONS

MODEL	SmartChef WSS2-1000
DIMENSIONS	1195 x 300 x 182mm high
WEIGHT	3kg
SHELF THICKNESS	30mm
COMPATIBILITY	(6x) 1/6 GN Pans

**ORDER CODE**                      **WSS2-1000**

## GN 1/6 INSERTS



**65mm**  
ORDER CODE      GNS8065



**100mm**  
ORDER CODE      GNS8100



**150mm**  
ORDER CODE      GNS8150

## WALL MOUNTED PLATE SHELF



### FEATURES

- Manufactured from high quality stainless steel

### SPECIFICATIONS

MODEL	SmartChef WSS1-1000
DIMENSIONS	1195 x 300 x 182mm high
WEIGHT	2kg
SHELF THICKNESS	30mm

**ORDER CODE**                      **WSS1-1000**

## WALL MOUNTED TICKET HOLDER



### FEATURES

- Manufactured from high quality stainless steel
- Paper held in place by marbles inside the clamping mechanism

### SPECIFICATIONS

MODEL	SmartChef NHZ1000
DIMENSIONS	1000 x 80mm high

**ORDER CODE**                      **NHZ1000**



**FEATURES**

- Manufactured from 0.8mm heavy duty stainless steel
- Rounded edges
- Anti-Jam system
- Reinforced corners



**FULL INSERTS**

**SPECIFICATIONS**

DIMENSIONS 325 x 530 x 20mm deep  
 CAPACITY 1.9Lt  
**ORDER CODE GNF8020**

DIMENSIONS 325 x 530 x 55mm deep (perforated)  
**ORDER CODE GNF8055.P**

DIMENSIONS 325 x 530 x 65mm deep (perforated)  
**ORDER CODE GNF8065.P**

DIMENSIONS 325 x 530 x 150mm deep  
 CAPACITY 18Lt  
**ORDER CODE GNF8150**

DIMENSIONS 325 x 530 x 55mm deep  
 CAPACITY 7.4Lt  
**ORDER CODE GNF8055**

DIMENSIONS 325 x 530 x 65mm deep  
 CAPACITY 9.4Lt  
**ORDER CODE GNF8065**

DIMENSIONS 325 x 530 x 100mm deep  
 CAPACITY 12.6Lt  
**ORDER CODE GNF8100**

**FULL LID**

**SPECIFICATIONS**

DIMENSIONS 325 x 530mm  
**ORDER CODE GNF8000**

**HERMETIC SEAL LID**

**SPECIFICATIONS**

DIMENSIONS 325 x 530mm  
**ORDER CODE PLA-HSL-11**



**1/2 INSERTS**

**SPECIFICATIONS**

DIMENSIONS 265 x 325 x 65mm deep  
 CAPACITY 3.5Lt  
 ORDER CODE **GNH8065**

DIMENSIONS 265 x 325 x 100mm deep  
 CAPACITY 5.5Lt  
 ORDER CODE **GNH8100**

DIMENSIONS 265 x 325 x 150mm deep  
 CAPACITY 8.5Lt  
 ORDER CODE **GNH8150**

**1/2 LID**

**SPECIFICATIONS**

DIMENSIONS 265 x 325mm  
 ORDER CODE **GNH8000**



**2/3 INSERTS**

**SPECIFICATIONS**

DIMENSIONS 325 x 352 x 20mm deep  
 CAPACITY 1.25Lt  
 ORDER CODE **GN2T8020**

DIMENSIONS 325 x 352 x 65mm deep  
 CAPACITY 5.25Lt  
 ORDER CODE **GN2T8065**

DIMENSIONS 325 x 352 x 150mm deep  
 CAPACITY 11.5Lt  
 ORDER CODE **GN2T8150**

**2/3 LID**

**SPECIFICATIONS**

DIMENSIONS 325 x 352mm  
 ORDER CODE **GN2T8000**



**1/3 INSERTS**

**SPECIFICATIONS**

DIMENSIONS 175 x 325 x 40mm deep  
 CAPACITY 1.5Lt  
 ORDER CODE **GNT8040**

DIMENSIONS 175 x 325 x 65mm deep  
 CAPACITY 2.25Lt  
 ORDER CODE **GNT8065**

DIMENSIONS 175 x 325 x 100mm deep  
 CAPACITY 3.5Lt  
 ORDER CODE **GNT8100**

DIMENSIONS 175 x 325 x 120mm deep  
 CAPACITY 3.5Lt  
 ORDER CODE **GNT8120**

DIMENSIONS 175 x 325 x 150mm deep  
 CAPACITY 5.5Lt  
 ORDER CODE **GNT8150**

**1/3 LID**

**SPECIFICATIONS**

DIMENSIONS 175 x 325mm  
 ORDER CODE **GNT8000**



**1/4 INSERTS**

**SPECIFICATIONS**

DIMENSIONS 162 x 265 x 65mm deep  
 CAPACITY 1.5Lt  
 ORDER CODE **GNQ8065**

DIMENSIONS 162 x 265 x 150mm deep  
 CAPACITY 3.75Lt  
 ORDER CODE **GNQ8150**

**1/4 LID**

**SPECIFICATIONS**

DIMENSIONS 162 x 265mm  
 ORDER CODE **GNQ8000**





**1/6 INSERTS**

**SPECIFICATIONS**

DIMENSIONS	160 x 175 x 65mm deep
CAPACITY	1Lt
ORDER CODE	<b>GNS8065</b>
DIMENSIONS	160 x 175 x 150mm deep
CAPACITY	2.25Lt
ORDER CODE	<b>GNS8150</b>

DIMENSIONS	160 x 175 x 100mm deep
CAPACITY	1.5Lt
ORDER CODE	<b>GNS8100</b>

**1/6 LID**

**SPECIFICATIONS**

DIMENSIONS	160 x 175mm
ORDER CODE	<b>GNS8000</b>



**1/9 INSERTS**

**SPECIFICATIONS**

DIMENSIONS	108 x 175 x 100mm deep
CAPACITY	0.8Lt
ORDER CODE	<b>GNN8100</b>

**1/9 LID**

**SPECIFICATIONS**

DIMENSIONS	108 x 175mm
ORDER CODE	<b>GNN8000</b>





**FEATURES**

- Large, backlit LCD display
- Stainless steel platform and column with ABS housed indicator
- Fitted with an internal rechargeable battery with up to 80hr lifetime
- Fitted with a built-in spirit level
- Easy to operate
- Fitted with (4x) adjustable, devise leveling feet

**PLATFORM SCALE**

**SPECIFICATIONS**

MODEL	TCS150
POWER SOURCE	220V or Internal battery
DIMENSIONS	400 x 500 x 600mm high
PLATFORM DIMENSIONS	400 x 500mm
MAX WEIGHT	150kg
ACCURACY	10g

**ORDER CODE** **SW/PSS0150**

**FEATURES**

- Manufactured from 430 Stainless steel
- Fully waterproof. IP68 rated certified
- Dual backlit LED display (front and rear)
- Fitted with a built-in spirit level
- Waterproof rubber keypad and an all-sealed PC board
- Fully Enclosed 6V/4Ah rechargeable battery inside
- Automatic power-off timing function
- Fitted with height adjustable feet



**WATERPROOF PORTION SCALE**

**SPECIFICATIONS**

MODEL	SmartChef JSF-15000
ELECTRICITY	220V / 6V Built-in battery
DIMENSIONS	297 x 246 x 127mm high
PLATFORM DIMENSIONS	230 x 190mm
WEIGHT	4.7kg
READABLE WEIGHT	15Kg
ACCURACY	0.5g

**ORDER CODE** **SW/PSS1015**

**DUAL DIGITAL DISPLAY**



**FEATURES**

- Fitted with a maintenance-free rechargeable battery
- Automatic fault detection, automatic calibration
- Overweight alarm function
- LCD display
- Supports a variety of weighing units
- Overload / impact protection
- Stainless steel weighing pan
- Fitted with a built-in spirit level



**PORTION SCALE**

**SPECIFICATIONS**

MODEL	JS15-05
POWER SOURCE	220V or Internal battery
DIMENSIONS	320 x 290 x 115mm high
PLATFORM DIMENSIONS	280 x 210mm
READABLE WEIGHT	15kg
ACCURACY	0.5g

**ORDER CODE** **SW/PSS0015**

**FEATURES**

- LCD display
- Overload and impact protection function
- 4V/4Ah rechargeable battery inside
- Sampling function
- Built-in spirit level
- Fitted with a Stainless steel pan
- Automatic fault detection and calibration
- Fixed tare weight
- Single item weight and accumulate function
- **No printer and not compatible with a printer**



**RETAIL SCALE - 15Kg**

**SPECIFICATIONS**

MODEL	SmartChef JSA 15-05
ELECTRICITY	220V / 4V Built-in battery
DIMENSIONS	320 x 290 x 115mm high
PLATFORM DIMENSIONS	280 x 210mm
WEIGHT	3kg
READABLE WEIGHT	15kg
ACCURACY	0.5g

**ORDER CODE** **SW/PSS2015**

**FEATURES**

- Stainless steel weighing platform pan
- Fast & accurate weighing results
- LCD display
- Supports a variety of weighing units
- 1.5V (2x) AA Batteries (not included)
- Equipped with a high precision strain gauge sensor
- Easy to operate
- Count / tare function
- USB interface / power supply



**KITCHEN SCALE**

**SPECIFICATIONS**

MODEL	LD5000S
POWER SOURCE	(2x) AA batteries or USB
DIMENSIONS	240 x 165 x 60mm high
PLATFORM DIMENSIONS	155 x 155mm
WEIGHT	0.5kg
READABLE WEIGHT	5kg
ACCURACY	1g

**ORDER CODE** **SW/PSS0005**

# INDEX

## A

<b>ANKARSRUM</b> Kitchen assistant .....	12-13
<b>ARISCO</b> Electric cooking ranges .....	36-37
<b>ARISCO</b> Gas cooking ranges with electric oven .....	35
<b>ARISCO</b> Tilting / Brat pans .....	38
<b>AVATHERM</b> Delivery boxes .....	176
<b>AVATHERM</b> Food pan carriers .....	178

## B

Back bar coolers .....	102, 135
<b>BAKEMARK</b> Convection ovens .....	74
<b>BAKEMARK</b> Deck ovens .....	84-87
<b>BAKEMARK</b> Dough divider .....	17
<b>BAKEMARK</b> Dough proofers .....	75
<b>BAKEMARK</b> Pastry sheeters .....	19
<b>BAKEMARK</b> Planetary mixers .....	14
<b>BAKEMARK</b> Spiral dough mixers .....	15
Baking ovens .....	78, 84-87
Baking trolleys .....	184
Beverage containers .....	177
Blades for Vege prep machine .....	6
Blast chillers .....	134
Blenders .....	7, 94
Boiling tables (Gas) .....	29
Bowl Cutters .....	8
Brat pans .....	38-39
Bread mixers .....	15
<b>BRICE</b> Modular ice machines .....	140-141
<b>BRICE</b> Self-contained ice machines .....	142

## C

Cake mixers .....	12-14
<b>CAMBRO</b> Beverage containers .....	177
<b>CAMBRO</b> CamTrays .....	173
<b>CAMBRO</b> Food pan carriers .....	177
<b>CAMBRO</b> GoBoxes .....	179-180
<b>CAMBRO</b> Insulated bases & domes .....	173
<b>CAMBRO</b> Insulated meal delivery system .....	173
<b>CAMBRO</b> Meal delivery carts .....	170-171
<b>CAMBRO</b> Serving trays .....	173
CamTrays .....	173
<b>CATERLOT</b> Coffee brewers .....	92
<b>CATERLOT</b> Urns .....	93
Cereal dispensers .....	125
Chafing dish heat elements .....	119
Chafing dish stands .....	118-119
Chafing dishes	
• Econo series .....	121
• Induction series .....	118-119
• PC cover series .....	122
• Window series .....	121
Char grillers (Gas) .....	30
Charcoal ovens .....	76-77
Chef bases .....	139
Chip cutters .....	9
Chip dumps .....	46
Chrome shelving .....	188
Cleaning trolleys .....	115
<b>CLEME</b> Slicers .....	11
Coffee brewers .....	92
Cold meat slicers .....	11
Combi steam ovens	
• Electricity .....	60-64, 67
• Gas .....	65
Cone bakers .....	53
Contact grills .....	48
Continuous sealers .....	24
Convection ovens .....	66, 68-69, 74
Conveyor toasters .....	50

Cooking ranges (Electric) .....	36-37
Cooking ranges (Gas) with electric oven .....	34-35
Cooking ranges with oven (Gas) .....	28
Cooking ranges	
• Electric (Full) .....	36-37
• Gas (Full) .....	28
• Gas (Electric oven) .....	34-35
<b>COOKRITE</b> Boiling tables (Gas) .....	29
<b>COOKRITE</b> Chef bases .....	139
<b>COOKRITE</b> Cooking ranges with oven (Gas) .....	28
<b>COOKRITE</b> Flat top griddles (Gas) .....	31
<b>COOKRITE</b> Gas fryers (Floor standing) .....	43
<b>COOKRITE</b> Radiant / Char grillers (Gas) .....	30
<b>COOKRITE</b> Salamanders (Gas) .....	51
<b>COOKRITE</b> Stands .....	32
Crepe makers .....	54
<b>CRYSTAL</b> Dishwashers (Front loading) .....	109
<b>CRYSTAL</b> Dishwashers (Hoodtype) .....	110-111
<b>CRYSTAL</b> Dishwashers (Conveyor) .....	112
<b>CRYSTAL</b> Display freezers .....	132-133
<b>CRYSTAL</b> Display fridges .....	132
<b>CRYSTAL</b> Ice cream scoop freezers .....	149
<b>CRYSTAL</b> Upright freezers .....	130, 132
<b>CRYSTAL</b> Upright fridges .....	130, 132
<b>CRYSTAL</b> Wok burners .....	40

## D

Deck ovens	
• Electric .....	78, 84-86
• Gas .....	87
Delivery bags .....	174-175
Delivery boxes .....	176
Deluxe coffee urns .....	127
Dishwashers	
• Conveyor .....	112
• Front loading .....	107, 109
• Hood-type .....	108, 110-111
Display cabinets	
• Heated .....	155, 157, 159
• Neutral .....	153, 157, 159
• Refrigerated .....	152, 154-156, 158
Display fridges .....	132
Double chamber vacuum sealers .....	22
Dough divider & rounder .....	17
Dough mixers .....	15-16
Dough proofers .....	75
Dough rollers .....	18
Dough sheeters .....	19

## E

<b>EKA</b> Combi steam ovens .....	60-65, 67
<b>EKA</b> Convection ovens .....	66, 68-69
<b>EKA</b> Gas cooking ranges with electric oven .....	34
<b>EMPERO</b> Bowl cutters .....	8
<b>EMPERO</b> Charcoal ovens .....	76-77
<b>EMPERO</b> Shawarma machines .....	40

## F

Faucets .....	113
Flat top griddles	
• Electric .....	47
• Gas .....	31, 47
Floor standing display cabinets .....	152-154, 156-159
Food pan carriers .....	177-180
Food processors .....	8
Food serving carts .....	172
Frappe makers .....	95
Freezers	
• Display freezers .....	132-137
• Ice cream scoop freezers .....	148-149, 164
• Upright storage freezers .....	130-132

## Fridges

• Back bar coolers .....	102, 135
• Display fridges .....	132
• Pizza ingredient fridges .....	136, 165
• Saladette cabinets .....	136-138
• Upright storage fridges .....	130-132
Fry cutters .....	9
Fryers	
• Electric (Floor standing) .....	42
• Electric (Table model) .....	45
• Gas (Floor standing) .....	43
• Pressure .....	44
<b>FURMIS</b> Delivery bags .....	174-175

## G

<b>GALILEO</b> Display cabinets .....	152-155
<b>GALILEO</b> Ice cream scoop freezers .....	148, 164
Gelato machines .....	98, 144
<b>GENERAL WAVE</b> Microwave ovens .....	52
Glass washers .....	106
GoBoxes .....	179-180
<b>GOSHEN</b> Gelato machines .....	98, 144
<b>GOSHEN</b> Soft serve machines .....	99, 145

## H

Hand wash basins .....	114
Hand-press impulse sealers .....	25
Heat elements for chafing dishes .....	119
Heat sealing machines .....	25
Heated Display cabinets .....	155, 157, 159
Horizontal continuous sealers .....	24
Hose reels .....	114
Hot water urns .....	93, 127

## I

Ice cream machines .....	98-101, 144-147
Ice cream scoop freezers .....	148-149, 164
Ice crushers .....	95
Ice machines	
• Modular .....	140-141
• Self-contained .....	142-143
<b>IGLOO</b> Display cabinets .....	156-159
<b>IGLOO</b> Open cooler merchandisers .....	161
<b>IGLOO</b> Open island merchandisers .....	162-163
<b>IGLOO</b> Sneezeguards .....	160
Impulse sealers .....	25
Induction chafing dishes .....	118-119
Induction cookers .....	41
Induction warmers .....	120
<b>INOXSERV</b> Cereal dispensers .....	125
<b>INOXSERV</b> Chafing dishes .....	118-122
<b>INOXSERV</b> Hot water urns .....	127
<b>INOXSERV</b> Inserts & lids .....	190-193
<b>INOXSERV</b> Juice dispensers .....	126
<b>INOXSERV</b> Soup kettles .....	124
Inserts & lids .....	190-193
Insulated bases & domes .....	173
Insulated meal delivery system .....	173

## J

Janitor trolleys .....	115
<b>JOHNY</b> Ice crushers .....	95
<b>JOHNY</b> Milkshake machines .....	95
Juice dispensers .....	96, 126

## K

Kitchen assistant .....	12
Kitchen scales .....	195
Knee operated hand wash basins .....	114
<b>KROMET</b> Tilting / Brat pans .....	39

## L

Laundry trolleys .....	115
------------------------	-----

## M

Manual lift toasters .....	50
Meal delivery bags .....	174-175
Meal delivery boxes .....	176
Meal delivery carts .....	170-171
Meat slicers .....	11
<b>MEC</b> Blast chillers .....	134
Merchandisers	
• Open cooler .....	161
• Open island .....	162-163
• Wall chillers .....	161
Microwave ovens .....	52
Milkshake machines .....	95
Mixers .....	12-16

## N

Neutral Display cabinets .....	153, 157, 159
--------------------------------	---------------

## O

<b>OMAKE</b> Crepe makers .....	54
<b>OMAKE</b> Flat top griddles (Electric) .....	47
<b>OMAKE</b> Flat top griddles (Gas) .....	47
<b>OMAKE</b> Waffle bakers (Belgian, Square) .....	55
<b>OMAKE</b> Waffle bakers (Round, Rotating) .....	56
<b>OMNIWASH</b> Dishwashers (Front loading) .....	107
<b>OMNIWASH</b> Dishwashers (Hood-type) .....	108
<b>OMNIWASH</b> Glass washers .....	106
Open cooler merchandisers .....	161
Open island merchandisers .....	162-163
Oven grids & pans .....	70, 88
Ovens	
• Charcoal ovens .....	76-77
• Convection ovens .....	66, 68-69, 74
• Combi steam ovens .....	60-65, 67
• Deck ovens .....	78, 84-87
• Microwave ovens .....	52
• Pastry ovens .....	66, 68-69, 74
• Pizza ovens .....	78-82
Overhead sprays .....	113

## P

Pastry sheeters .....	19
Pie warmers .....	164
Pizza delivery bags .....	174-175
Pizza dough rollers .....	18
Pizza ingredient fridges .....	136, 165
Pizza ovens .....	78-82
Planetary mixers .....	12-14
Plate shelf .....	189
Platform scales .....	194

# INDEX

## P

CONTINUED

<b>POLARCAB</b> Back bar coolers .....	102, 135
<b>POLARCAB</b> Display freezers .....	133
<b>POLARCAB</b> Juice dispensers .....	96
<b>POLARCAB</b> Pizza ingredient fridges .....	36, 165
<b>POLARCAB</b> Saladette cabinets .....	136-138
<b>POLARCAB</b> Self-contained ice machines .....	143
<b>POLARCAB</b> Slush machines .....	97
<b>POLARCAB</b> Soft serve machines .....	100, 146
<b>POLARCAB</b> Upright freezers .....	131
<b>POLARCAB</b> Upright fridges .....	131
Polony slicers .....	11
Portion scales .....	194-195
Potato chippers .....	9
Pre-rinse sprays .....	113
Pressure fryers ( <i>Electric</i> ) .....	44
<b>PRISMAFOOD</b> Dough rollers .....	18
<b>PRISMAFOOD</b> Pizza ovens .....	78, 82
<b>PRISMAFOOD</b> Spiral dough mixers .....	16
Proofers .....	75

## Q

## R

Rack trolleys .....	184-185
Radiant grillers ( <i>Gas</i> ) .....	30
Refrigerated Display cabinets .....	152, 154-156, 158
Retail scales .....	195
Rice cookers .....	52

## S

Saladette cabinets .....	136-138
Salamanders .....	51
Sandwich toasters .....	49
Scales	
• Platform scales .....	194
• Portion scales .....	194-195
• Retail scales .....	195
Serving trays .....	173
Shawarma machines .....	40
Shelving	
• Chrome shelves .....	188
• Spice shelf .....	189
• Plate shelf .....	189
Single chamber vacuum sealers .....	23
Slicers .....	11
Slush machines .....	97
<b>SMARTBLEND</b> Blenders .....	7, 94
<b>SMARTCHEF</b> Baking trolleys .....	184
<b>SMARTCHEF</b> Chip dumps .....	46
<b>SMARTCHEF</b> Chrome shelving .....	188
<b>SMARTCHEF</b> Cleaning trolleys .....	115
<b>SMARTCHEF</b> Cone bakers .....	53
<b>SMARTCHEF</b> Contact grills .....	48
<b>SMARTCHEF</b> Conveyor toasters .....	50
<b>SMARTCHEF</b> Electric fryers ( <i>Table model</i> ) .....	45
<b>SMARTCHEF</b> Electric fryers ( <i>Floor standing</i> ) .....	42
<b>SMARTCHEF</b> Electric pressure fryers .....	44
<b>SMARTCHEF</b> Flat top griddles ( <i>Electric</i> ) .....	47
<b>SMARTCHEF</b> Fry cutters .....	9
<b>SMARTCHEF</b> Knee operated hand wash basins .....	114
<b>SMARTCHEF</b> Pie warmers .....	164
<b>SMARTCHEF</b> Pizza ovens .....	80-81
<b>SMARTCHEF</b> Rack trolleys .....	184-185
<b>SMARTCHEF</b> Rice cookers .....	52
<b>SMARTCHEF</b> Salamanders ( <i>Electric</i> ) .....	51
<b>SMARTCHEF</b> Sandwich toasters .....	49
<b>SMARTCHEF</b> Soft serve machines .....	101, 147

<b>SMARTCHEF</b> Spiral potato cutter .....	10
<b>SMARTCHEF</b> Tea trolleys .....	182-183
<b>SMARTCHEF</b> Ticket holders .....	189
<b>SMARTCHEF</b> Toasters .....	50
<b>SMARTCHEF</b> Vegetable preparation machines .....	6
<b>SMARTCHEF</b> Waffle bakers ( <i>Round</i> ) .....	58
<b>SMARTCHEF</b> Waffle bakers ( <i>Square</i> ) .....	57
<b>SMARTCHEF</b> Waffle lolly bakers .....	57
<b>SMARTCHEF</b> Wall mounted shelving .....	189
<b>SMARTCHEF-i</b> Induction cookers .....	41
<b>SMARTCHEF-i</b> Induction warmers .....	120
<b>SMARTVAC</b> Continuous sealers .....	24
<b>SMARTVAC</b> Impulse sealers .....	25
<b>SMARTVAC</b> Vacuum sealers .....	22-23
<b>SMARTVAC</b> Wrapping machines .....	25
<b>SMARTWAY</b> Scales .....	194-195
Smoothie makers .....	7, 94
Sneezeguards .....	160
Soft serve machines .....	99-101, 145-147
Soup kettles .....	121, 124
Soup warmers .....	119
Spice shelf .....	189
Spiral dough mixers .....	15-16
Spiral potato cutter .....	10

## T

<b>T&amp;S</b> Faucets .....	113
<b>T&amp;S</b> Hose reels .....	114
<b>T&amp;S</b> Pre-rinse sprays .....	113
Table model display cabinets .....	155, 164
Tea trolleys .....	182-183
Ticket holders .....	189
Tilting pans .....	38-39
Toasters	
• Contact grills .....	48
• Conveyor .....	50
• Manual lift .....	50
• Sandwich .....	49
Tray clearing trolleys .....	181
<b>TRAYPORT</b> Food serving carts .....	172
<b>TRAYPORT</b> Tray clearing trolleys .....	181

## U

Upright freezers .....	130-132
Upright fridges .....	130-132
Urns .....	93, 127

## V

Vacuum sealers .....	22-23
Vegetable preparation machines .....	6
Vertical continuous sealers .....	24
<b>VOLLRATH</b> Fry cutters .....	9

## W

Waffle bakers	
• Belgian .....	55, 57
• Cone bakers .....	53
• Lolly ( <i>waffle on a stick</i> ) .....	57
• Round .....	56, 58
Wall chillers .....	161
Wall mounted shelving .....	189
Wok burners .....	40
Wrapping machines .....	25

## X • Y • Z

## **WESTERN CAPE**

11 Uranium street, Triangle Farm, Bellville, Cape Town  
+27 21 949 7325  
info@catermarket.co.za

---

## **GAUTENG**

11 Milano close, Cosmo business park, Cosmo City, Johannesburg  
+27 11 708 0191  
jhb@catermarket.co.za

---

## **KWAZULU-NATAL**

Unit 5 Villa Commercial Park, 5 Garlicke Drive, Ballito, Dolphin Coast  
+27 32 648 0092  
kznadmin@catermarket.co.za

[www.catermarket.co.za](http://www.catermarket.co.za)



## **DISCLAIMER**

CaterMarket has made every effort to ensure that the information contained in this catalogue at the time of publishing is true and accurate. However, neither CaterMarket nor their associated agents can guarantee that this information is accurate at all times.

Images used are only for illustration purposes and may vary from the actual product.

CaterMarket reserves the right to make any changes considered necessary, at any time and without warning, to improve its products. As a result CaterMarket accepts no responsibility or liability that may arise through the reliance of the information contained herein.

CaterMarket strictly prohibits the reproduction, even partial, of images, text, etc of this catalogue for commercial purpose, without specific authorisation by CaterMarket.



**SmartChef**

**IGLOO**

**JOHNY**
**arisco**

**CRYSTAL**  

**SMARTBLEND**
**Gosher**

**POLAR CAB**

**omniWASH**
**SmartWay**  
**CAMBRO**

**aterLot**

**prismafood**  
**solutions**

**EMPERO**
**omake**

**T&S**  

**BakeMark**
**CookRite**
**inoxserv**
**Galileo**

**CRYSTAL**

